



SPH
STEPP PREMIX HEATERS



OPERATIONS/MAINTENANCE/PARTS MANUAL

LP and Diesel Burner Systems



Warranty

Stepp Manufacturing Company Inc. hereby warrants to the original purchaser that products manufactured by Stepp Mfg. will be free from defects in material and workmanship for a period of one (1) year from the date of purchase.

Stepp Mfg., at its discretion, will provide for the repair or replacement of any part found upon examination by Stepp Mfg. to be defective, except as noted below. Such repair or replacement will be free of charge to the original purchaser for a period of one (1) year from the date of purchase, except as noted below.

No warranty is extended to cover:

- Product pump wear or damage caused by foreign objects.
- Routine maintenance, cleaning, and adjustments.
- Parts/components that have been altered, misused, or improperly adjusted or maintained.
- Transportation to and from the place of warranty repair.
- Removal of material from equipment.

The following items are covered solely by their manufactures warranty:

- Engines
- Hydraulic components
- Burners
- Pumps
- Tires
- Other component parts

The following items are covered by a pro-rata warranty:

- Hoses that carry heated materials.
- Heating elements for hoses and wands.

Disclaimer of further warranty:

Stepp Mfg. makes no warranty, expressed or implied, other than this warranty. The implied warranties of merchantability and fitness for particular purpose are hereby disclaimed. Repair or replacement of products or parts proving to be defective in material or workmanship shall be the exclusive remedy for breach of this warranty.

Stepp Mfg. shall not be liable for incidental or consequential damages including but not limited to: damages for inconvenience, rental or purchase of replacement equipment, for loss of profits, loss of material, or other loss resulting from breach of this warranty.

Stepp Mfg. reserves the right to incorporate any changes in design into its products without obligation to make such changes on products previously manufactured.

Please see Warranty section for more details.

Stepp Manufacturing Co., Inc.
12325 River Road
North Branch, MN 55056
P: 651-674-4491 F: 651-674-4221
www.steppmfg.com

INTRODUCTION

SPH Stepp Premix Heater Trailer

Thank you for selecting *Stepp* highway maintenance equipment. We are confident you will be satisfied with the *Stepp Premix Heater Trailer*. *Stepp Manufacturing* is backed by over 70 years of experience in the design and manufacture of highway maintenance equipment. This experience along with our innovative design and unique features make the *Stepp Premix Heater Trailer* the fastest and most efficient available. Continued research and development, along with input from you, the user, help make this possible.

To assure safe operation of this equipment, the operator must read and understand all operating procedures and safety notices contained in this manual. In addition, the operator *must* receive instruction from their supervisor, or the manufacturer, on how to safely operate the *Stepp Premix Heater Trailer*. Contact the manufacturer if any questions arise or if you desire training for additional staff members.

Operating instructions, adjustments and periodic maintenance procedures are given so you, the operator, can keep your unit working like new and expect many years of dependable service from it. Remember, any machine, regardless of design or type, will perform only in relation to the way it is operated and the maintenance it receives.

Read this manual carefully and observe all Warnings and Cautions. If you have any recommendations or comments regarding this manual, please send them attention to: Engineering Dept., Stepp Manufacturing Co. Inc., 12325 River Road, North Branch MN. 55056-6225 or call 651-674-4491. All comments we receive are reviewed and may be incorporated into future manuals.

When ordering parts or making any inquiry about the *Stepp Premix Heater Trailer*, be sure to include the model number and VIN found on the data plate attached to the frame.

TABLE OF CONTENTS

Introduction	3
Contents	5
Warnings, Cautions, Notes	6
Operations	7
Maintenance	15
Troubleshooting	19
Replacement Parts	27
Warranty Guide	33
Watlow Programming	39
Schematics	49
Tire Information	Insert

IMPORTANT NOTICE!

This manual contains cautions and warnings that alert you to potential safety issues.

WARNING is used to inform you of conditions or operations that could cause serious injury or death.

CAUTION is used to inform you of conditions or operations that could cause damage to the equipment.

NOTE is used to provide you with additional information that may be helpful or useful for a particular situation.

This manual explains the basic operations, maintenance and use of the Stepp SPH Pre-Mix Heater. The main objective of this equipment is to maintain heat in patching material in order to repair paved surfaces.

Before Starting or Operating this Machine

Understand and observe all the following **Warnings**, **Cautions**, and **Notes**.

WARNINGS

- ◆ This equipment contains mechanical and heating components that may cause serious injury or death if not handled or maintained properly. All personnel must be properly trained in the operation and maintenance of this equipment.
- ◆ Before refueling, shut off the burners and allow all flames in the burner and pilot light to extinguish. Shut off the engine.
- ◆ Check fuel lines, fuel line connections, and all other components for leaks. If any leaks are found, they must be repaired before using the unit.
- ◆ Know the temperature required for the material being used, and do not exceed this temperature. Avoid over heating, as this may cause equipment damage, personal injury, and/or death.
- ◆ Never load a tank with heated oil when moisture is present in the tank. Depending on the temperature of the hot oil, the moisture may instantly boil causing hot oil to foam up and out of the tank causing severe burns.
- ◆ Do not operate the tack tank burner when the amount of material in the tank is less than 4" above the flues. Allow 10 minutes cool-down time after the burner has been shut off before exposing the flues. Exposed flues will over-heat and cause an explosion and/or fire.
- ◆ The tack tank cover must be unlatched when operating the tack tank burner. This is to provide for emergency venting, in the event of a flash, to prevent the tank from exploding.

CAUTIONS

- ◆ Know the materials being used and know the proper handling, heating, application, clean-up, and storage procedures. Not all materials are compatible with each other. Many materials have a very limited shelf life. Most materials require special handling procedures to prevent personal injury and/or equipment damage. Contact your material supplier and/or manufacturer for proper handling instructions. Equipment malfunction or damage due to improper handling or use of the materials is not covered by warranty.
- ◆ Do not exceed the maximum heating temperature or storage time as recommended by the material manufacturer. This may cause emulsion type materials to separate and become difficult or impossible to remove from the machine. Consult with the material manufacturer for recommendations.
- ◆ Over-agitation or circulation may cause emulsion type materials to separate and become difficult or impossible to remove from the machine. Consult with the material manufacturer for recommendations.
- ◆ Do not mix *Anionic* and *Cationic* materials together, as the materials attach to each other and will become difficult or impossible to remove from the machine. If you are not sure consult your material supplier.

NOTES

- ◆ Become familiar with the Material Safety Data Sheet (MSDS) for the material being used in the machine and take appropriate safety precautions. Wear the proper clothing and protective gear as recommended by the MSDS and your safety director.
- ◆ DO NOT use the equipment unless it is in good condition.
- ◆ In case of skin contact with hot materials, dip into **cool, clean water immediately**. Do not wipe the product, as this will spread the burn.
- ◆ Consult the MSDS and contact your safety director for proper extinguishing of petroleum based fires.
- ◆ Carry a fire extinguisher(s) as recommended by your safety director.
- ◆ Notify your supervisor or the manufacturer if any questions arise concerning the operation of this equipment.

OPERATIONS

OPERATIONS

Transporting

WARNING: Prior to transporting, the driver of the tow vehicle must assure the safety of the operation. The driver must also know, and assure, the product temperature is within limits.

Trailer Hook-up

1. Connect trailer to towing vehicle
 - a. Assure hitch is engaged properly.
 - b. Attach safety chains to towing vehicle.
 - c. Connect battery charging circuit to tow vehicle if required. (see illustration below)
 - d. Connect electrical plug to towing vehicle.
 - e. Connect breakaway cable to towing vehicle.
 - f. Check operation of lights and brakes.
2. Secure trailer for transport
 - a. Shut OFF the engine and burners.
 - b. Shut OFF all fuel valves.
 - c. Be sure the product temperature is not above the recommended operating temperature.
 - d. Securely latch the tank cover.

Charging Circuit Connection

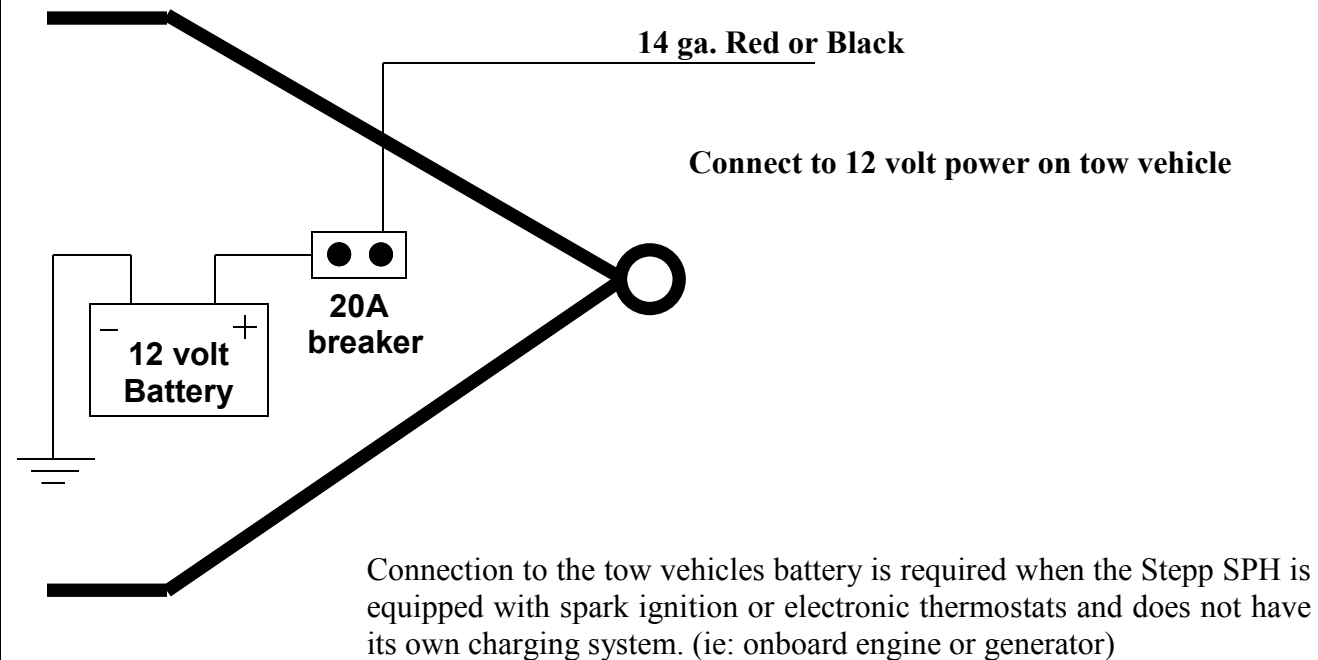

OPERATIONS

Loading

WARNING: *Hydraulic equipment can crush any object with tremendous force causing injury or death. Keep yourself and all other persons clear when operating hydraulic equipment.*

1. Manually operated doors

- a. Open doors using the telescopic handles on the top of each door. Open the left door first (or front door if hinged front and rear) and use the handle locking ring to lock door open.
- b. Check that no foreign material has entered the equipment.
- c. Check that the proper material is being used.
- d. Fill the hopper box with the desired amount of material (do not over-fill or doors won't close).
- e. Close doors (close right hand door first).

2. Hydraulic operated doors (optional)

- a. Open doors by moving the hydraulic control in the proper direction.
- b. Check that no foreign material has entered the equipment.
- c. Check that the proper material is being used.
- d. Fill the hopper box with the desired amount of material (do not over-fill or doors won't close).
- e. Close doors by moving the hydraulic control in the proper direction.



OPERATIONS

LP Burner w/ Thermostat

NOTE: *This system uses electrical sparks to ignite the pilot lights that in turn ignite the burners. If the pilot light goes out, the system will attempt a re-ignition. If the re-ignition is not successful, the gas supply will automatically be shut off and the system must be vented before resetting the system. The system is reset by switching the 12 volt power supply OFF then ON again. By use of a thermostat, the system automatically controls the burners to maintain the desired product temperature.*

Igniting Burner

1. Turn OFF burner and pilot valves.
2. Attach Liquid LP bottle to system and set regulator between 10 to 20 PSI depending on intensity of flame desired.
3. Open pilot light valve.
4. Turn on main power switch and a "clicking" sound can be heard as the ignition system starts to work.
5. When the pilot light ignites, proceed to next step. If ignition has failed, reset power switch. **NOTE:** *The ignition system is designed to sense flame at the pilot light to act as flameout protection. If flame is not present within approximately six seconds, the ignition igniter will drop out and require resetting with the power switch.*

WARNING: *The burner chamber will require venting to eliminate the possibility of gas build up after each ignition reset.*

6. Open burner valve then set thermostat to the desired temperature and the burner will ignite.
7. Operate engine or other charging circuit as necessary to provide power to the thermostat and spark ignition system.

Tack Tank Burner (option)

1. Attach Liquid LP bottle to system and set regulator at 10 to 20 psi. Depending on intensity of flame desired.
2. Open tack tank burner valve.
3. Set thermostat at desired temperature.
4. Turn on main power switch and a "clicking" sound can be heard as the ignition system starts to work.
5. If ignition has failed, reset power switch.

To Shut Off Burners

1. Turn off power switch on the control box. **CAUTION:** *When storing the equipment, turn off fuel supply tank valve and allow the fuel system to burn off. This will prevent temperature changes from building excess pressure in the system and possibly damaging components. Then turn Off the power switch.*

OPERATIONS

LP Burner w/ Baso Valve

NOTE: *When equipped with a Baso Safety Valve, this system will shut off the gas supply to the burners if the flame should go out for any reason. This system is not equipped with automatic temperature controls. It is the operators responsibility to shut off the burners when the product reaches the recommended temperature. Allow for temperature “creep” when the burners are shut off.*

Igniting Burner

1. Verify that the main burner valve and lighting wand valve are OFF.
2. Attach Liquid LP bottle to system and set regulator between 10 to 20 PSI, depending on intensity of flame desired.
3. Open pilot light control valve between four to six turns.
4. Open lighting wand valve $\frac{1}{4}$ to $\frac{1}{2}$ turn and light immediately to prevent gas build-up and fire hazard.
5. Insert lighting wand near outlet of pilot light.
6. Push the button on the safety control valve (baso valve).
7. Once the pilot light has ignited, hold the button down 30-45 seconds, or until it stays energized by itself.
8. Once the pilot light is lit and the Baso Valve is staying in the operating position, close valve on lighting wand and store.
9. Open the main burner valve slowly until you acquire the desired flame.

To Shut Off Burners

1. Turn off the burner control valve and allow the burner to self-extinguish.
2. Close pilot light valve.

CAUTION: *When storing the equipment, turn off fuel supply tank valve and allow the fuel system to burn off through the lighting wand. This will prevent temperature changes from building up excess pressure in the system and possibly causing damage to the equipment, or personal injury and/or death.*

OPERATIONS

Diesel Burner w/ Thermostat

NOTE: This system incorporates a 12 volt burner and blower assembly and burns #2 diesel fuel. A 12 volt battery and charging circuit supply power to the burner, blower motor, and thermostat. The charging circuit may consist of an engine driven alternator mounted on the unit, or a hook-up to the tow vehicles charging system. The thermostat will automatically control the burners to maintain the desired temperature. The temperature of the material is shown on LCD digital displays.

Igniting Burner

1. Check fuel tank for proper fuel type and quantity.
2. Set thermostat to the product manufacturers recommended level.
3. Turn ON burner power switch and the burner will ignite.
4. Operate battery charging device.

To Shut Off Burner

1. Set thermostat to the lowest setting.
2. Turn OFF burner power switch.

CAUTION: The burner requires a minimum of 12 volts for proper operation. Poor combustion with excessive smoke and lack of heat or burner malfunction will result with lower voltage. Assure the battery is fully charged and the charging circuit is operating properly for maximum performance.



Tack Tank (optional)

An optional tack tank is available to pre-heat the tack oil used to obtain better repairs. The tack tank incorporates its own heating system similar to the systems used to heat the Premix Heater. Burner operating instructions for the tack tank are included with the burner instructions for the Premix Heater main hopper on the previous pages.

Pumping System (optional w/ tack tank)

An optional pump may be installed on the tack tank to pump the tack material through dispensing equipment, such as a hose and wand. The pump may be driven by a gas or diesel engine, or by an electrical or hydraulic system. The plumbing must be purged of tack material when finished to prevent plumbing freeze-up. This is done by reversing the pump to suck the material out of the system. An optional flush tank may also be installed to further flush the system of any remaining material.

1. **Circulate.** In this operation the contents of the tack tank are pumped through the wand pressure control valve and directed back to the tank to aid in heating and mixing.
 - a. Set wand pressure control valve to "Recirculate" position.
 - b. Set valve on top of tank to "Product" position.
 - c. Engage pump in "Forward" direction.
2. **Spray Wand.** In this operation the contents of the tank are pumped to the spray wand for application to the road surface.
 - a. Set wand pressure control valve to "Wand" position.
 - b. Set valve on top of tank to "Product" position.
 - b. Engage pump in "Forward" direction.
 - c. Open valve on spray wand to apply tack material.
3. **System Purge.** (suck back) In this operation the pump is "Reversed" to purge the product from the system.
 - a. Disengage pump.
 - b. Set wand pressure control valve to "Wand" position.
 - c. Set valve on top of tank to "Product" position.
 - d. Open valve on wand, then engage pump in "Reverse" for two minutes.
 - e. Close valve and disengage pump.

4. **System Flush.** (optional) Flushing solvent is pumped through the pump and wand to clean material from the system.

WARNING: *Do not allow flushing solvent to contaminate the contents of the tack tank.*

- a. Disengage pump.
- b. Set wand pressure control valve to "Wand" position.
- c. Set valve on top of tank to "Flush" position.
- d. Place end of wand into suitable container. **NOTE:** *Do not allow flushing solvent to splash out of container.*
- e. Engage pump in "Forward" position, then open the wand valve to flush.
- f. When complete, disengage pump and close valves.
- g. Dispose of flushing solvent in accordance with local, state, and federal laws.

Tack Tank- Low Level Shut Down (optional)

This system incorporates a float in the tack tank that is hooked to a switch. When the tack material reaches a level several inches above the flues, the burner or heater will be shut off to prevent equipment damage. This eliminates the need of someone continuously monitoring the level in the tack tank. The function of the low level shutdown must be checked on a daily basis by the equipment operator and the calibration should be checked every six months and adjusted as necessary by a qualified technician.

1. Operational Check (daily)

- a. Ignite burner following the appropriate instructions.
- b. Manually trip the low level shutdown switch located on the float shaft. This should cause the burner to shutdown. If the burner does not respond correctly, contact a qualified service technician or call the manufacturer.

2. Calibration Check (every 6 months)

- a. Verify that the burner shuts down when the product reaches a level no less than 4" above the flues.
- b. Adjust by loosening the set screw on the switch cam and rotating the cam as necessary.
- c. Tighten set screw and verify adjustment.

Overnight Heaters (optional)

The overnight heaters are designed to preheat, or maintain the temperature of the heat transfer oil up to the capacity of the heating elements. This will decrease the amount of time necessary to bring the materials up to the recommended application temperatures.

The burner is automatically disconnected from the system and the electric heating elements are activated when the power cord is plugged in. The thermostats are set by the operator to prevent overheating.

1. To Activate Overnight Heaters

- a. Plug electrical cord into an outlet with a minimum 15 amp capacity and 120 volts.
- b. Set thermostats to recommended temperature provided by the material manufacturer, then turn on the heating control power switch. System operation is now automatic.

CAUTION: *Do not exceed the material manufacturers recommended heating cycles or heating times (pot life).*

Washdown Pump (optional)

The washdown pump is used to spray solutions on the shovel platform and your tools for clean-up, and to reduce sticking of the asphalt material.

To reduce the risk of fire, the burner is automatically disconnected from the system when the washdown selector switch is activated. However, the operator should verify that the burner is actually off for increased safety, in case of a malfunction in the system.

WARNING: *Washdown solutions may be extremely flammable, use caution and avoid spraying solution near any hot components, sparks, or flame. DO NOT smoke while operating the washdown pump.*

1. To Activate Washdown Pump

- a. Place washdown selector switch in the "Washdown Pump" position.
- b. Verify burner has extinguished.
- c. Spray solution as needed. Avoid heated components, sparks, or flame.

MAINTENANCE

PRE-MIX HEATER MAINTENANCE SCHEDULE

ITEM	OPERATION TO PERFORM	DAILY	EVERY WEEK	EVERY MONTH	EVERY 3MO	EVERY 6MO	EVERY YEAR
Burner Diffuser	Inspect burner diffuser for damage and deterioration.				X		
Burner Diffuser	Replace burner diffuser. Refer to parts list for P/N						X
Burner Fuel Nozzle	Replace fuel nozzle. Refer to parts section for P/N						X
Door Hinges And Slides	Lubricate with high temperature grease. Inspect for worn or damaged components.				X		
Hose Assembly On Spray Wand	Inspect for cracks, fraying, or deterioration. Replace if needed with original equipment hose.		X				
Hose Assembly On Spray Wand	Replace with original equipment hose						X
Main Hopper	Clean out and inspect for cracks or other damage. Weld or repair as needed						X
Tack Tank (if equipped)	Cleanout and inspect for leaks, cracks or other damage.						X
Fuel Filter for Burner	Install new filter for diesel burner. Install new strainer for LP burner.					X	
Thermostats	Check for proper calibration, adjust as needed.	X					
Fuel Lines	Check for security, damage, and leaks. Replace with oem type hose as needed	X					
Fuel Tanks	Check for damage and leaks.	X					
Lights	Check for proper operations	X					

PRE-MIX HEATER MAINTENANCE RECORD

DATE	MAINTENANCE PERFORMED	HOUR METER	SERVICED BY

All maintenance items must be performed according to the maintenance schedules and documented for warranty coverage to be effective.

TROUBLE SHOOTING

TROUBLE SHOOTING

Diesel Burner

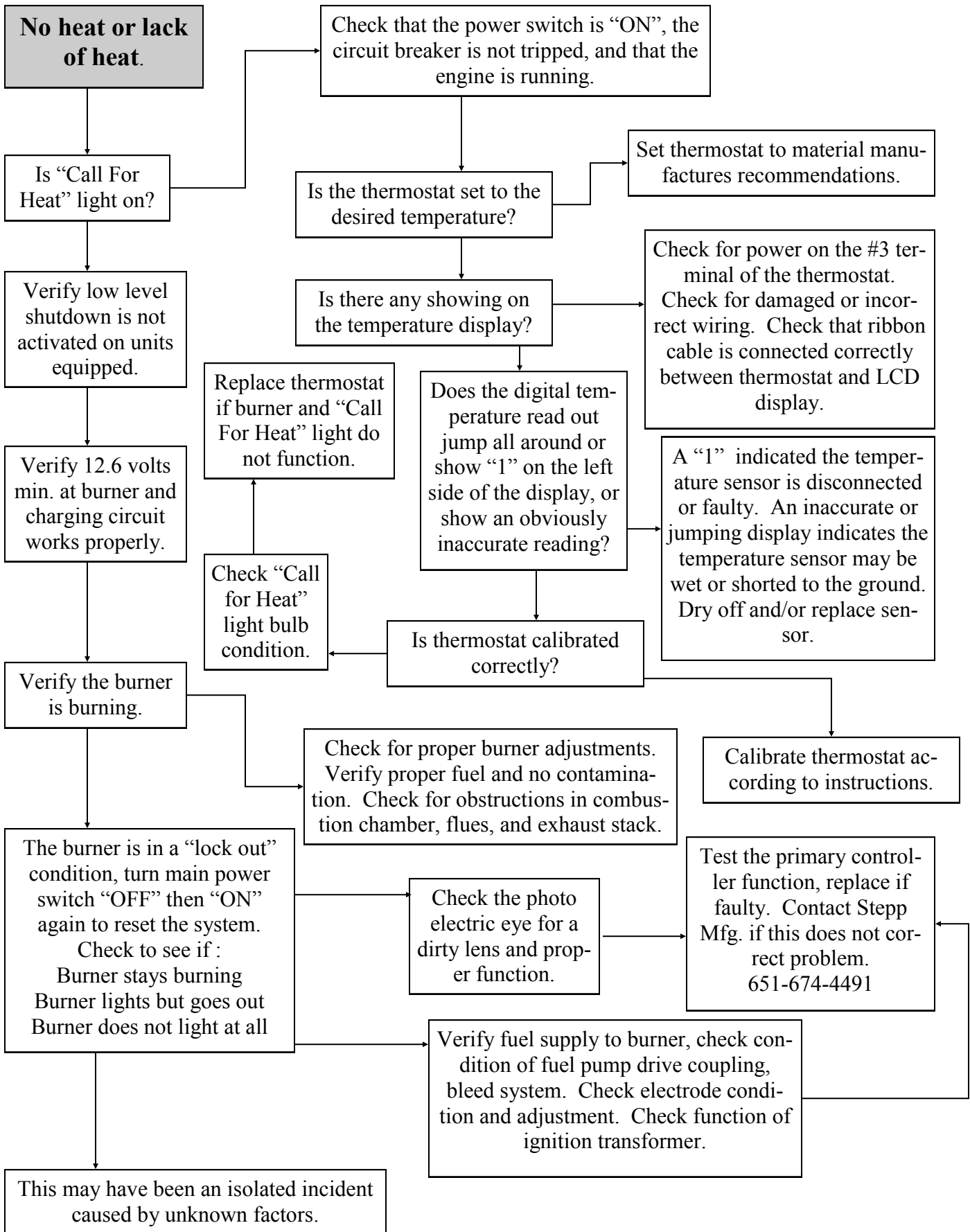

Diesel Burner Adjustments

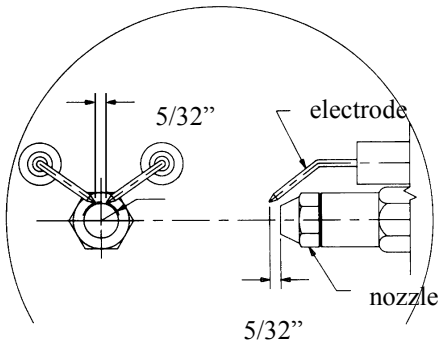

Electrode Adjustment - Fig.1

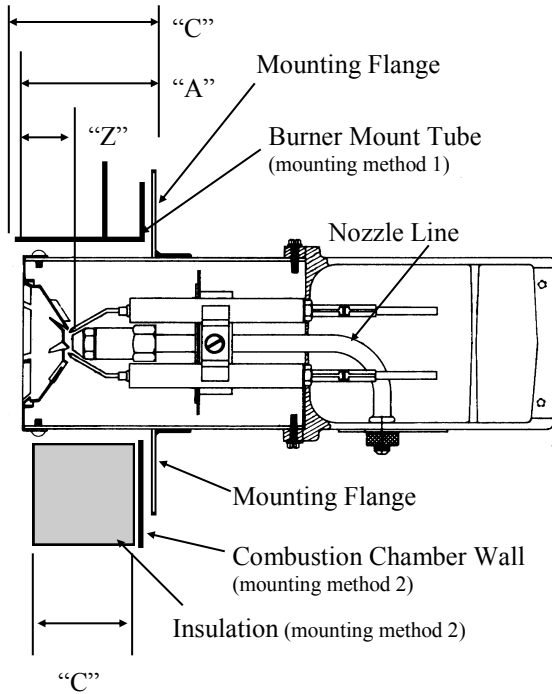

Dimensional Adjustments - Fig. 2

NOZZLE FLOW CHART																
100 PSI	.75	.85	.90	1.00	1.10	1.20	1.25	1.35	1.50	1.65	1.75	2.00	2.25	2.50	2.75	3.00
140 PSI	.89	1.00	1.07	1.18	1.30	1.41	1.48	1.60	1.78	1.95	2.07	2.37	2.66	2.96	3.25	3.55

Fig. 3

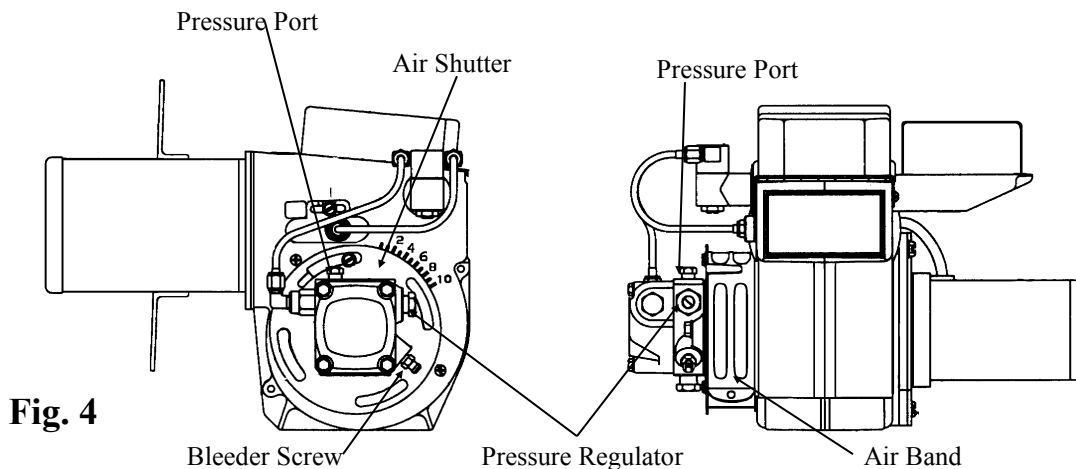
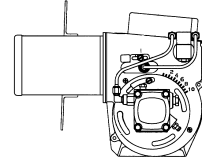

Fig. 4

1. Bleed all air from fuel system through bleeder screw. See Fig. 4 (burner motor must be running).
2. Check and adjust igniter electrodes as shown in Fig. 1.
3. Verify dimensional adjustments. The “Z” in dimension is set to 1 1/8” by repositioning the nozzle line. The “A” dimension is set 1/4” less than the “C” dimension by repositioning the mounting flange. Refer to the mounting methods shown in Fig. 2.
4. Check and adjust fuel pressure to 140 psi. 100 psi minimum may be used to compensate for high altitude operations (refer to Fig. 3).
5. Set initial adjustment of air band and air shutter to number six. Ignite the burner and adjust the air supply until there is a slight amount of smoke. See Fig. 4.
6. Allow temperature to rise to at least 150° F. then readjust air supply until there is just a trace of smoke.
7. Using combustion analyzer, measure the CO₂ or O₂ levels. Then increase the air supply to *reduce* the CO₂ by 1%, or *increase* the O₂ by 1%. If an analyzer is not available, increase the air supply until the smoke just disappears.
8. Tighten all screws after final adjustments are made.

Primary Controller Burner MTD/Hard Wired

NOTE: *The primary controller can be bench tested for proper operation using an automotive type, 12 volt battery as a power source. Refer to the wiring schematics for wire identification.*



1. Remove controller from burner. Mark all wires for proper reassembly.
2. Using two test lights, or volt meters, connect one to the blue wire, and one to the white/orange wire of the controller. Connect the black leads of your test instruments to the negative (-) terminal of the battery.
3. Connect the black wire from the controller to the negative (-) terminal of the battery.
4. Connect the red, white/red, and the white wires together, then connect these three wires to battery (+) terminal. Both test instruments should show voltage for approximately 15 seconds. After 15 seconds, the controller should "lock out" and no voltage will be present.
5. Repeat step #4, only this time connect the two yellow wires from the controller together three seconds after applying power to the three wires of the controller. (This simulates the controller receiving a "flame" signal from the photo electric eye). The white/orange wire should show voltage as long as the controller is hooked to the battery. The blue wire should only show voltage for about 15 seconds. Replace the controller if it fails any of these tests.

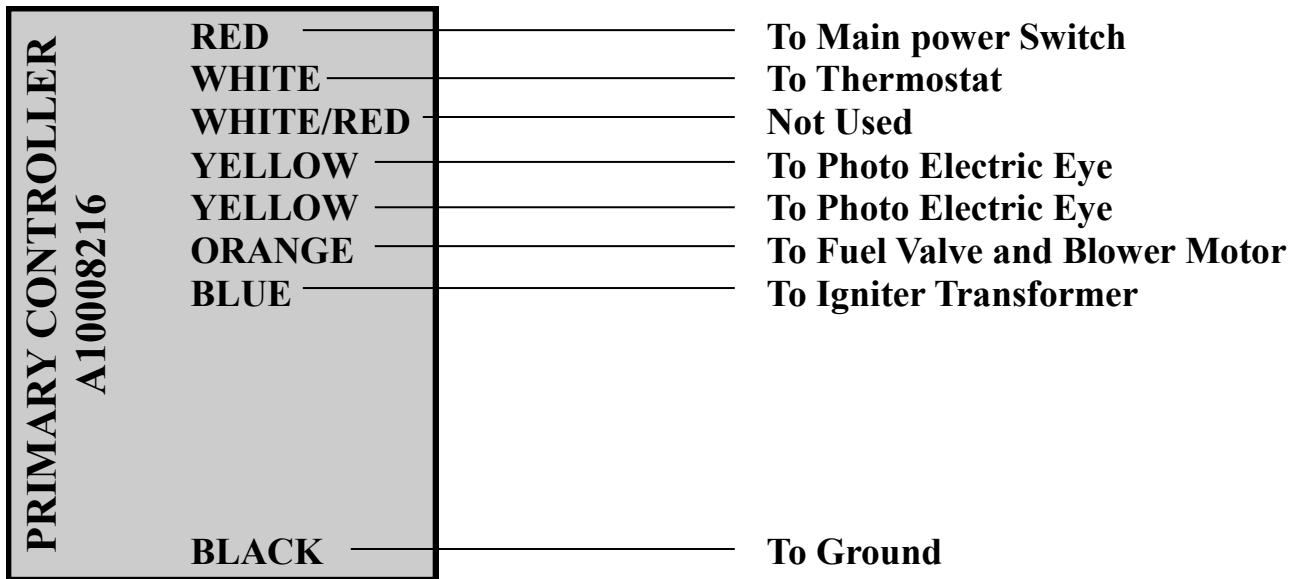
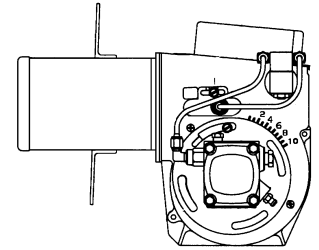

Photo Electric Eye

NOTE: The Photo Electric Eye can be bench tested for proper operation using an ohm meter. Assure the lens of the Photo Electric Eye is clean prior to testing.

1. Block off all light to the Photo Electric Eye. Test across the leads with your ohm meter; you should get an infinite resistance reading (a lot of resistance).
2. Point the Photo Electric Eye at a light source, the brighter the light, the less resistance your ohm meter will show. **CAUTION:** Replace the Photo Electric Eye if it does not respond in this way.



Fuel Valve

NOTE: The Fuel Valve can be bench tested for proper operation using an automotive type 12 volt battery as a power source.

1. Disconnect the two leads and remove the fuel lines from the fuel valve.
2. The valve should be closed when no power is available.
3. Apply 12 volts to the two leads and the valve should open. **CAUTION:** Replace the fuel valve if it does not respond in this way.

Ignition Transformer

WARNING: Shock hazard, high voltage up to 20,000 volts.

1. Assure that 12 volts is being supplied to the transformer during the ignition cycle. (Refer to the Primary Controller tests.)
2. Check electrode condition and adjustment. Replace or adjust as necessary. **CAUTION:** Replace ignition transformer if unit won't produce sparks.

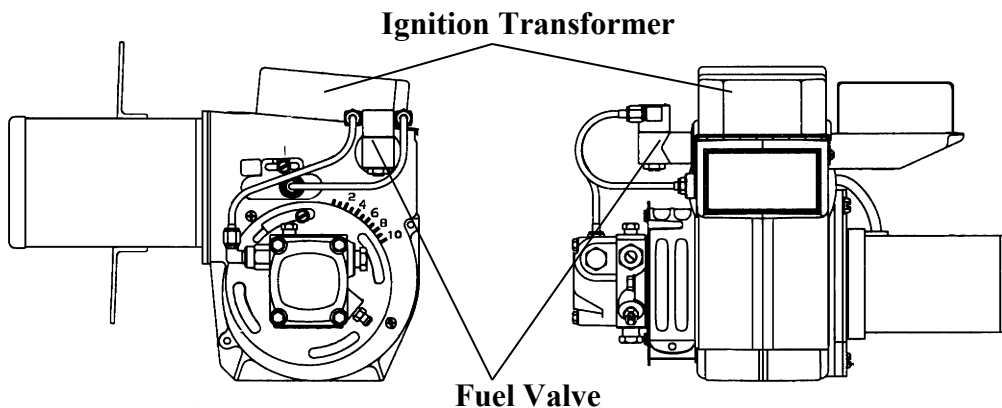

TROUBLE SHOOTING

LP Burner Spark Ignition

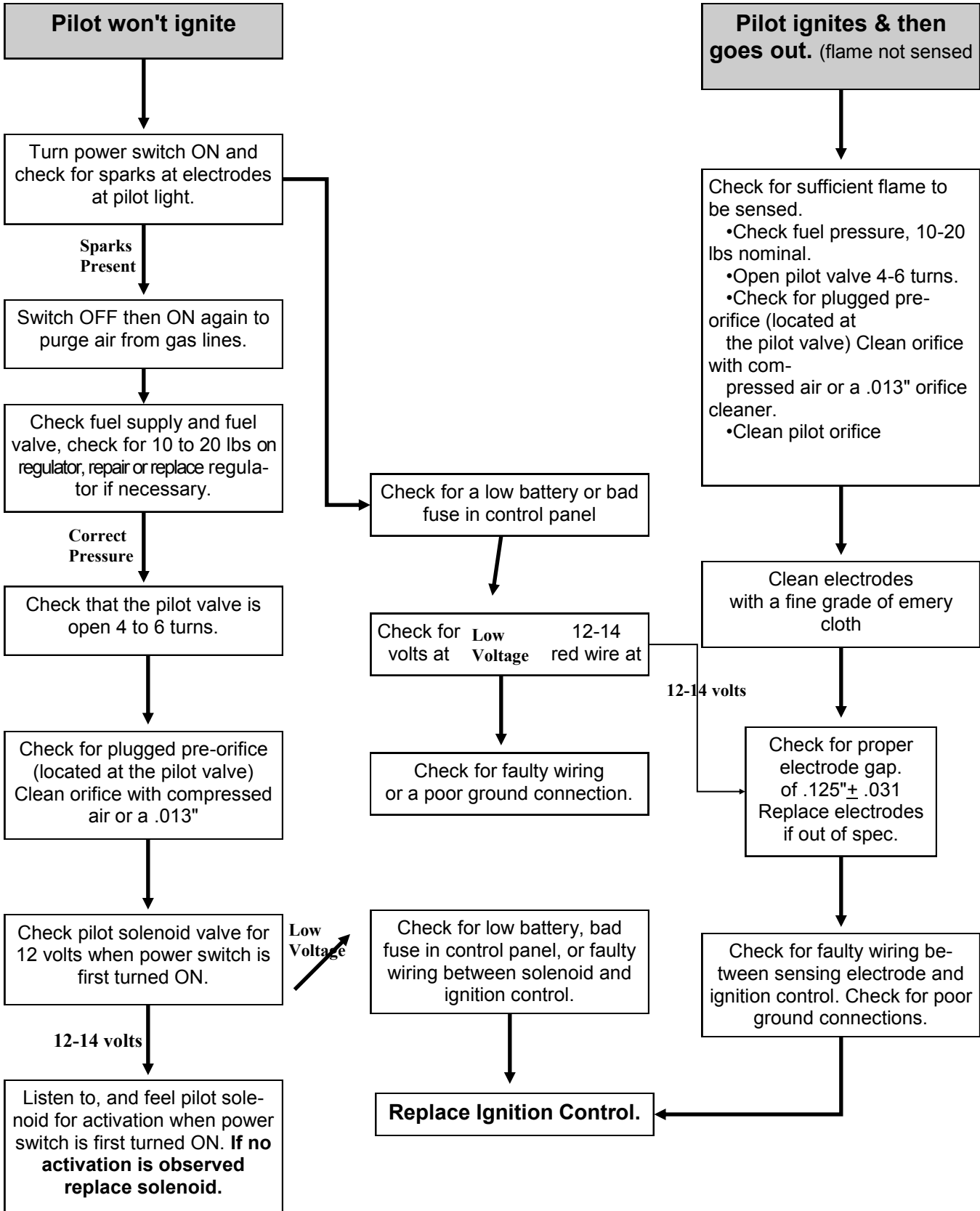

Fuel Valve Solenoid

The fuel solenoid valve needs to be removed to perform this test. 12 volts applied to the fuel solenoid valve activates an electromagnet that pulls the valve open. With no power applied, a spring pushes the valve closed. Blow through the valve to verify proper operation. Replace valve if not functioning properly.

Fenwal Ignition Control

The Fenwal Ignition Control creates sparks at the electrodes for igniting the pilot light, and supplies power to the fuel valve at the appropriate times. The controller receives voltage from either the thermostat or main power switch (depending on the system) to begin operation. A flame sensing circuit is incorporated for control of the fuel valve if the flame goes out.

When the power switch is turned on, or when the thermostat calls for heat, a 12 volt signal is sent to the controller. The controller will then create sparks at the electrodes. At the same time, the controller also sends a 12 volt signal to the fuel valve causing it to open. This allows fuel into the pilot light and it is ignited by the sparks at the electrodes.

The flame sensing circuit will signal the controller that ignition was successful. The controller will then shut off the sparks. The fuel valve will remain open to keep the flame burning.

If the controller does not sense a flame within approximately six to seven seconds, it will shut off the fuel supply and the sparks. The controller will then "lock out".

If the flame should go out for any reason, the controller will try for re-ignition, if re-ignition is not successful in six to seven seconds, the controller will "lock out".

If a lock out situation occurs, the main power switch must be shut off, then on again, to reset the system. (continued on next page)

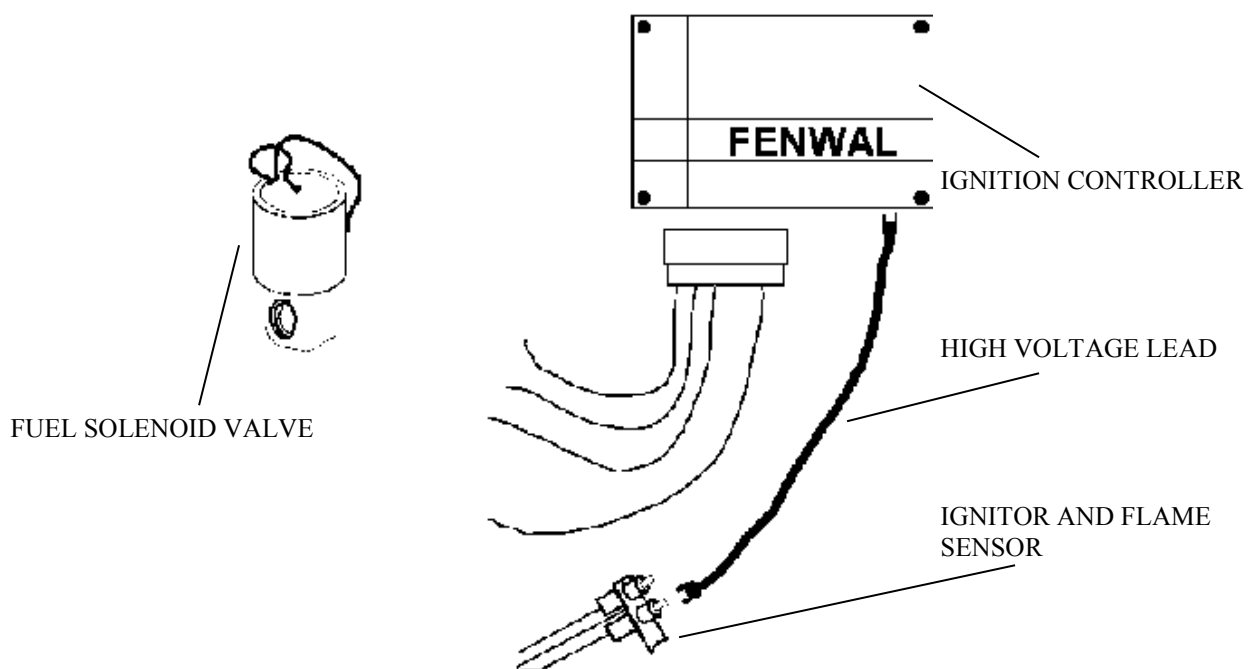

TROUBLE SHOOTING

Fenwal Ignition Tests

Fenwal Ignition Control

The Ignition Controller can be tested for proper operation using an automotive type 12 volt battery as a power source. A propane torch, and a 12 volt test light will also be needed. Do not use a digital volt/ohm meter, as it may give false readings for these tests.

1. Disconnect wires as necessary to perform these tests. Mark all wires for proper reassembly.
2. Connect one lead of your test light to the brown wire from the fuel valve. Connect the other lead to neg. (-) terminal of battery.
3. Be sure the yellow wire from the controller is connected to ground. (neg. terminal of battery).
4. While observing your test light, apply power to the red wire on the controller by turning on the main power switch and thermostat (if equipped). The test light should light up and sparks will be present at the electrodes for approximately six seconds, then the controller should "lock out." The sparks will stop and the test light will go out.
5. Repeat step #4, only this time direct flame from a propane torch across the sensing and ground electrodes two seconds after applying power to the controller.
6. The sparks should stop and the brown wire (fuel valve) should show voltage as long as the flame is directed across the electrodes.
7. Remove the flame and the sparks should reappear for six seconds; this is the trial for re-ignition. If the flame is not re-established, the system "locks out".
8. Be certain all wiring is correct and undamaged, then replace the controller if it fails any of these tests.

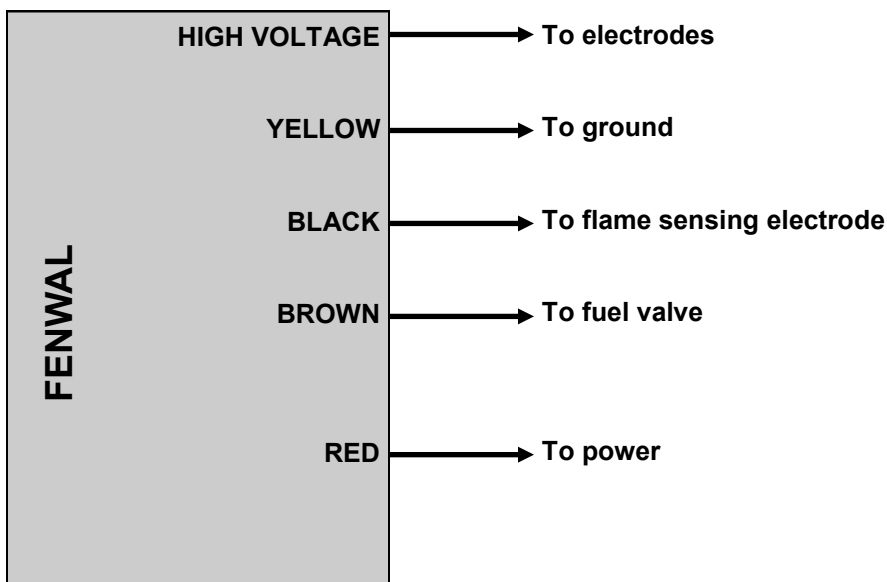

REPLACEMENT PARTS

REPLACEMENT PARTS

Diesel Burner

Original Equipment Replacement Parts

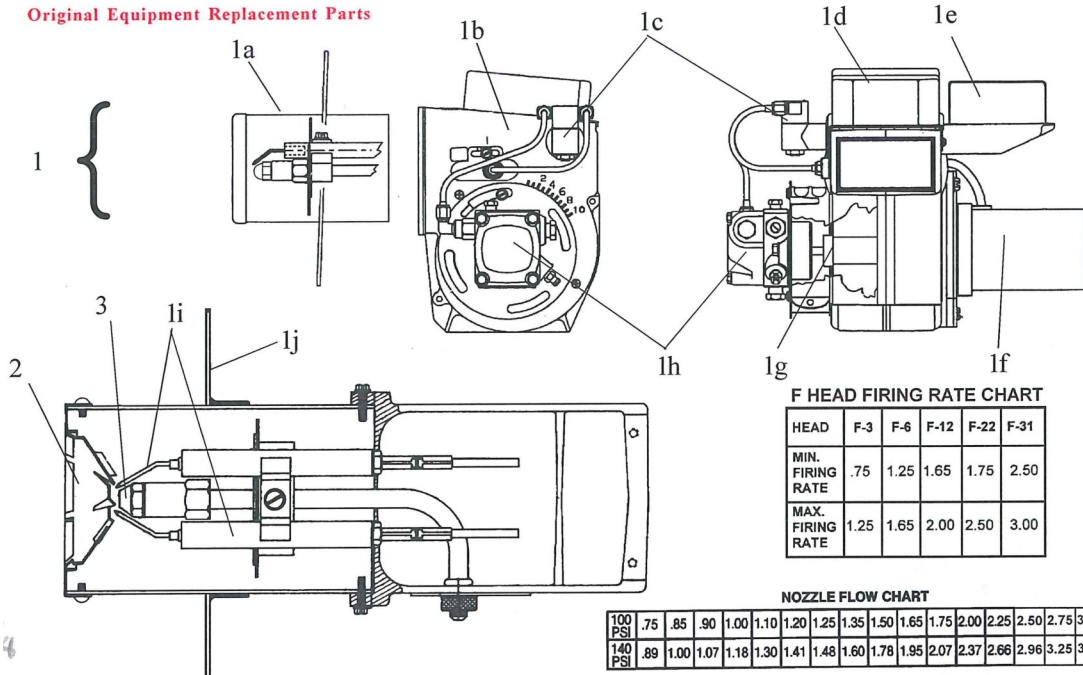

F HEAD FIRING RATE CHART

HEAD	F-3	F-6	F-12	F-22	F-31
MIN. FIRING RATE	.75	1.25	1.65	1.75	2.50
MAX. FIRING RATE	1.25	1.65	2.00	2.50	3.00

NOZZLE FLOW CHART

	.75	.85	.90	1.00	1.10	1.20	1.25	1.35	1.50	1.65	1.75	2.00	2.25	2.50	2.75	3.00
100 PSI	.75	.85	.90	1.00	1.10	1.20	1.25	1.35	1.50	1.65	1.75	2.00	2.25	2.50	2.75	3.00
140 PSI	.89	1.00	1.07	1.18	1.30	1.41	1.48	1.60	1.78	1.95	2.07	2.37	2.66	2.96	3.25	3.55

ITEM	QTY	DESCRIPTION	PART#
1	1	Burner assembly w/ Primary Control (less fuel retention head and nozzle)....	A10008215
1	1	Burner assembly, complete w/ fuel retention head and nozzle	A10008105-010
1a	1	Air Tube	509070
1b	1	Photo electric eye (under ignition transformer)	
		-With Connectors	A10007678
		-Without Connectors	P10007720
1c	1	Valve, fuel control.....	509091
1d	1	Ignition Transformer	509087
1e	1	Primary Controller	P10001034
		-Weather Pack/Weather Pack.....	A10007216
		-Weather Pack/CPC New Style.....	A10008216
1f	1	Motor, blower.....	509092
1g	1	Coupling, pump to motor	509086
1h	1	Pump, burner fuel.....	509094
**	1	Pump, burner fuel- Internal Fuel Shut-off Valve.....	509109
1i	1	Electrode, igniter set.....	509089
1j	1	Mounting Flange	509071
**	1	Blower Fan Wheel.....	509069
2	1	Fuel retention head, F3 (for .75 to 1.25 gph).....	P10005134
3	1	Nozzle, .75 gph. 80°	P10005136
**	1	Fuel Filter Element.....	509078

** Not Shown

Note: Indented item numbers with letter suffix are included with preceding item number.

Nozzle GPH rated at 100 psi. Match nozzle and fuel retention head with that installed.

REPLACEMENT PARTS

LP Burner

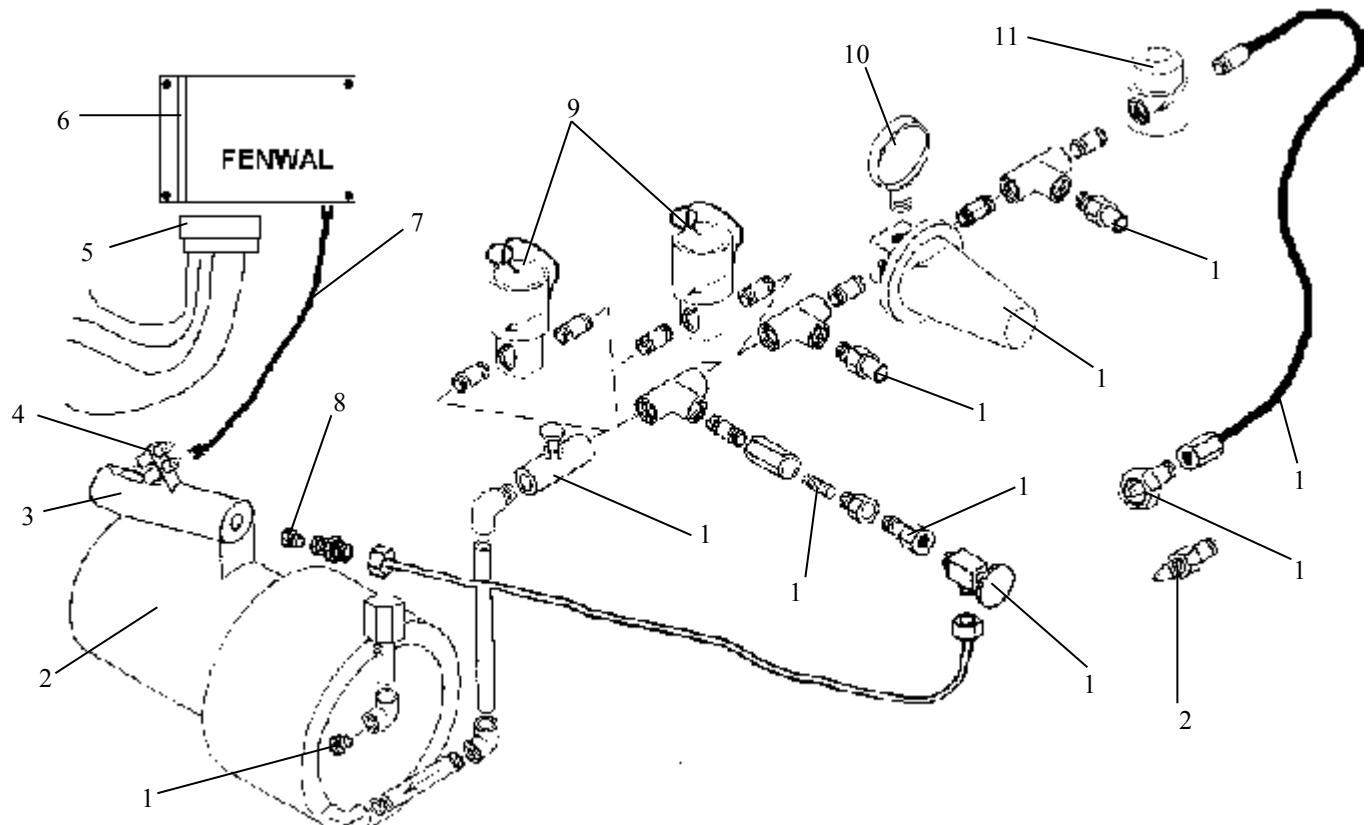

ITEM	QTY	DESCRIPTION	PART#
1	1	Orifice, main burner	call
2	1	Burner assembly	call
3	1	Pilot light, spark ignition	901101
4	1	Ignition electrode & flame sensor assy.	P10005738
5	1	Low voltage cable assembly	P10005737
6	1	Ignition control box	P10005719
7	1	High voltage cable assembly	P10005736
8	1	Orifice, pilot light, .035	P10005718
9	2	LP Solenoid valve assembly, 12V	P10005720
**	2	Solenoid winding only, for LP Solenoid valve	509051
10	1	Pressure gauge	P10005630
11	1	Lp filter (element only)	509028
12	2	LP relief valve (location may vary)	P10005656
13	1	LP regulator	P10002936
14	1	Pre-orifice, pilot light, .013	509005
15	1	Strainer, pilot light	P10005653
16	1	Valve, pilot light	P10005652
17	1	Valve, burner - V104	P10005655
18	1	.25 x 5' LP hose	P10005685
	1	.25 x 10' LP hose (optional)	523004
19	1	Pol fitting, liquid LP - female (recommended)	P10005657
20	1	Pol fitting, vapor LP - male	509021

(** Not Shown)

REPLACEMENT PARTS

LP Burner w/ Baso Valve

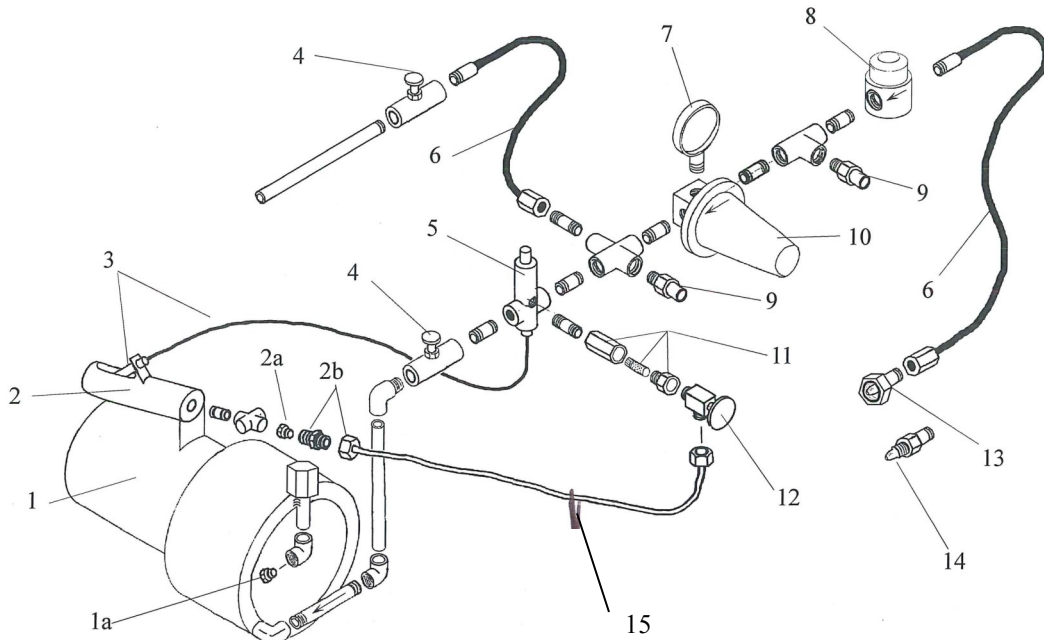

ITEM	QTY	DESCRIPTION	PART#
1	1	Burner assembly (depending on application)	call
1a	1	Orifice, main burner, (depending on application).....	call
2	1	Pilot light.....	901100
2a	1	Orifice, pilot light	P10005662
2b	1	Jet Fitting, pilot light.....	M10005660
3	1	Thermocouple, 72"- New Style	P10005658
4	2	Valve, LP, V104	P10005655
5	1	Baso valve (safety valve) -New Style.....	P10006972
6	2	.25 x 5' LP hose.....	A10007881-060
	2	.25 x 10' LP hose (optional).....	523004
7	1	Pressure gauge	P10005630
8	1	LP filter assembly-complete	P10005654
8a	1	Filter element only (not shown).....	509028
9	2	LP relief valve (location may vary)	P10005656
10	1	LP regulator	P10002936
11	1	Strainer, pilot light	P10005653
12	1	Valve, pilot light	P10005652
13	1	Pol fitting, liquid LP - female (recommended).....	P10005657
14	1	Pol fitting, vapor LP - male	509021
**	1	ACME fitting, liquid LP	P10007921
15	1	Gas tube, Pilot Light	P10005689

** Not Shown

REPLACEMENT PARTS

Controls

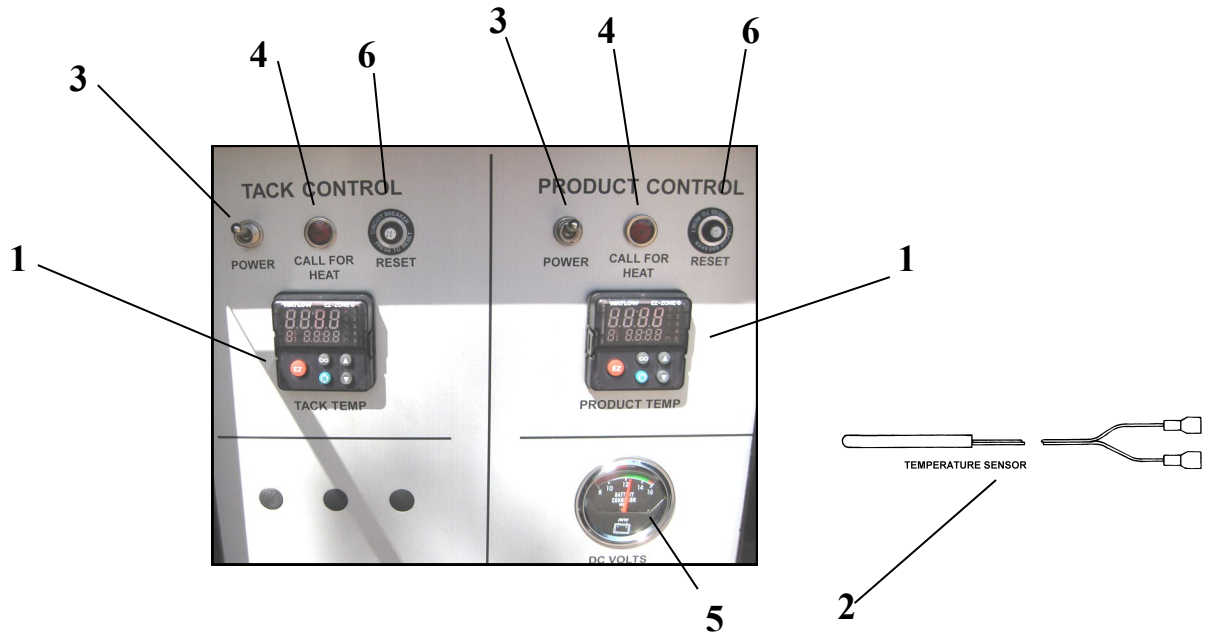

ITEM	QTY	DESCRIPTION	PART#
1	-	Thermostat, Watlow 0-550°, (12volt)	P10003540
2	-	Sensor, RTD Watlow 0-550°, (12volt)	A10001017
3	-	Switch- SPST Toggle ON/OFF	P10000180
4	-	Light- Call For Heat 12V	P10000181
5	-	Volt Meter	P10000184
6	-	20 Amp Breaker	P10000179

** Not Shown

REPLACEMENT PARTS

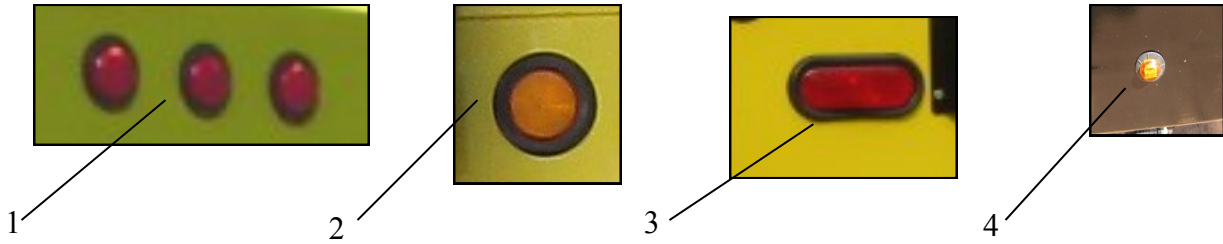

Misc. Parts

ITEM	QTY	DESCRIPTION	PART #
1	3	Light 2.5" Red Clearance	P10002892
2	4	Light 2.5" Amber Clearance	P10002893
3	2	6" Oval Stop-Tail Turn Light	P10002899
4	2	Light Clearance LED 3/4" Amber	P10002894
5	1	Whelen Beacon	P10000777

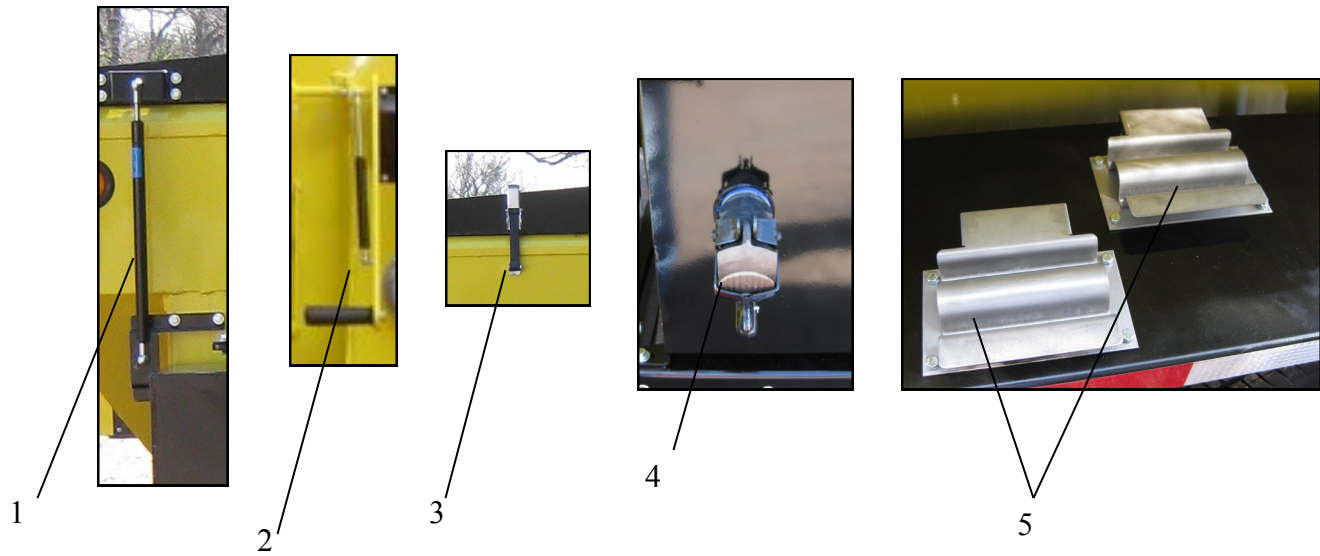

Item	QTY	DESCRIPTION	PART#
1	2	Top Door Gas Shocks/Spring -100#	P10002423
2	1	Unloading Door Gas Shocks/Spring -30#	P10002422
3	2	Top Door Hood Latch	P100054130
4	4	Stainless Steel Tool Holder	P10003766
5	1	2" Molasses Gate Valve- Tack Tank	P10004713
**	1	Valve 1/4" 2 Way	P10000155
**	1	Tack Tank Gasket	P10007686
6	1	Hose Reel	P10007448
7	1	Winch- Compactor Plate Carrier	P10002298
8	1	Fuel Pump 12v DC- Wash Down System	P10000156
9	1	Fuel Filler Cap- Wash Down System	P10001133



Consumer Warranty Guide



Introduction

Congratulations on your purchase of equipment built by Stepp Manufacturing for your asphalt maintenance needs. Your equipment has been designed and constructed to give you the most in performance, ease of use, and reliability. It is our desire that you will find operating the equipment both productive and profitable.

Warranty Procedures Through A Dealer

If your equipment requires repair, or needs parts for repair, please contact your area dealer. For repairs, the unit must be brought to the dealer for warranty. The dealer will require purchase date information, where the machine was purchased, and the Vehicle Identification Number (VIN) of the equipment. This information is needed so the dealer can submit a warranty claim. The dealer will repair your equipment, once warranty is approved, at no charge to you under the provisions of the warranty policy.

Warranty Procedures Direct Through The Factory *(when no servicing dealer is available in your area)*

Contact Stepp Manufacturing's Customer Service Department at (651) 674-4491.

In this situation, it may be advantageous for you to repair the machine and be reimbursed direct from the factory for warranty repairs. If you do not have the facilities, or the technicians, to perform the repair, the unit can be brought to a local repair facility. In either case, Stepp Manufacturing **MUST** be contacted and authorize the warranty repair **PRI-OR** to any work being performed. If work is done prior to authorization, the warranty will not be honored.

If parts are required for the warranty repair, contact Customer Service at Stepp Manufacturing for replacements. When warranty replacement parts are shipped to you, a Warranty Authorization Number will be issued. If asked to return the defective parts, "tag" the defective parts with the Warranty Authorization Number, then package them in the same box the new parts were shipped in. Ten (10) business days will be allowed for return of the defective parts. If the defective part is not received back at the factory within this allotted time, the warranty will not be honored.

You will be billed for all parts shipped that require returning of defective parts. However, when the defective parts are returned and evaluated, you will receive credit for the cost of the part only. Thus, it is important that all defective parts are turned to Stepp Manufacturing in the allotted ten (10) day period.

Engine Warranty Claims

When a warranty issue develops with the engine, bring the unit to the engine manufacturer nearest authorized service center for repair. Be prepared to supply them with proof of purchase information with purchase dates.

Stepp Manufacturing cannot process engine warranty claims. However, we will be happy to offer assistance in locating the nearest service center.

Equipment Owner Responsibilities

As the equipment owner, you are responsible for:

- Using the equipment in accordance with the correct operating procedures as shown in the operators manual.
- Assuring all maintenance items are completed in accordance with the operators/maintenance manuals.
- Transporting the equipment to the place where warranty repairs can be completed.
- Supplying purchase date and VIN information to establish warranty coverage.



**General Warranty Statement
Stepp Manufacturing's One (1) Year Limited Warranty**

Stepp Manufacturing Co., Inc. hereby warrants, to the original purchaser of new equipment, that products manufactured by Stepp Manufacturing will be free from defects in material and workmanship for a period of one (1) year from the date of purchase from Stepp Manufacturing.

Stepp Manufacturing, at its discretion, will provide for the repair or replacement of any part found, upon examination by Stepp Manufacturing, to be defective, except as noted below. Such repair or replacement shall be free of charge to the original purchaser of new equipment for a period of one (1) year from the date of purchase, except as noted below.

No warranty is extended to cover:

- Product pump wear or damage caused by foreign objects.
- Routine maintenance, cleaning, and adjustments.
- Parts or components that have been altered, misused, improperly adjusted, or improperly maintained.
- Transportation to and from the place of warranty repair.
- Removal of materials from equipment.

The following items are covered solely by their manufacturer's warranty:

- Engines
- Hydraulic components
- Burners
- Pumps
- Axles
- Tires
- Other component parts not solely manufactured by Stepp Manufacturing

The following items are covered by a pro-rata warranty:

- Hoses that carry heated materials
- Heating elements for material hoses and wands

Disclaimer of further warranty:

Stepp Manufacturing makes no warranty, expressed or implied, other than this warranty. The implied warranties of merchantability and fitness for a particular purpose are hereby disclaimed. Repair or replacement of products or parts proving to be defective in material or workmanship shall be the exclusive remedy for breach of this warranty.

Stepp Manufacturing shall not be liable for incidental or consequential damages. Including, but not limited to, damages for inconvenience, rental or purchase of replacement equipment, loss of profits, or other loss resulting from breach of this warranty.

Stepp Manufacturing reserves the right to incorporate any changes in design into its products without obligation to make such changes on products previously manufactured.



**Twelve (12) Month Pro-Rata Limited Warranty
Heated Asphalt Hose and Heating Elements**

Effective for Equipment Delivered After 5/1/2012

Stepp Manufacturing Co., Inc. hereby warrants to the original purchaser, on a pro-rated basis, that the heated asphalt hose and heating elements installed on NEW Stepp Manufacturing's equipment shall be free from defects in material and workmanship for period of twelve (12) months for the heated asphalt hose and six (6) months for the heating element.

In the event that a heated asphalt material hose or a heating element fails under normal use during the warranty period, Stepp Manufacturing will supply a replacement heated asphalt hose or heating element, along with one-half (0.5) hour for installation labor on a pro-rated adjustment basis.

- If the failure occurs under normal use within the first three (3) months from date of purchase, Stepp Manufacturing will supply a replacement, and provide for one-half (0.5) hour installation labor at no charge to the customer.
- If the failure occurs under normal use within the fourth (4th) through twelfth (12th) months, Stepp Manufacturing will supply a replacement, and provide for one-half (0.5) hour installation labor on a pro-rata basis.

The pro-rated adjustment is based on the total number of months elapsed since the purchase date of the new equipment from Stepp Manufacturing. This rate is then applied to the one-half (0.5) hour labor rate and the current suggested retail price of the proper replacement heated asphalt hose or heating element supplied by Stepp Manufacturing. This is the amount the customer will have to pay. Freight will not be included in the reimbursement. If a new heated asphalt hose or heating element is needed prior to warranty inspection, you will be billed for all parts shipped that require returning of defective parts. However, when the defective parts are returned and evaluated, you will receive credit for the cost of the part only. **Thus, it is important that all defective parts are turned in to Stepp Manufacturing in the allotted ten (10) day period, or warranty will be denied.**

In no case will the warranty coverage extend beyond the six (6) month period for the heating element or the twelve (12) month period for the heated asphalt hose, from the original purchase date of the new equipment from Stepp Manufacturing. *Physical damage is not covered by this warranty.* Physical damage may include, but is not limited to:

- Broken heating element (typically caused by repeated bending to less than a one (1) foot radius).
- Heated asphalt hoses burnt from the inside (typically caused by operating the heating element in an empty hose).
- External cuts or abrasions on the heated asphalt hose (typically caused by dragging on the ground).

The chart below shows the pro-rated amount, by percentage, that will be allowed by warranty, pending examination of the heated asphalt hose or heating element.

Heated Asphalt Hose		
Failure Date	Warranty's Responsibility	Customer's Responsibility
0-3 Months <i>0-90 Days</i>	100%	0%
3-6 Months <i>91-180 Days</i>	70%	30%
6-7 Months <i>181-211 Days</i>	60%	40%
7-8 Months <i>212-242 Days</i>	50%	50%
8-9 Months <i>243-273 Days</i>	40%	60%
9-10 Months <i>274-304 Days</i>	30%	70%
10-11 Months <i>305-335 Days</i>	20%	80%
11-12 Months <i>336-365 Days</i>	10%	90%
After 12 Months	0%	100%

Heating Element		
Failure Date	Warranty's Responsibility	Customer's Responsibility
0-3 Months <i>0-90 Days</i>	100%	0%
3-4 Months <i>91-121 Days</i>	60%	40%
4-5 Months <i>122-152 Days</i>	40%	60%
5-6 Months <i>153-180 Days</i>	20%	80%
After 6 Months	0%	100%



Warranty Claim Authorization Number: _____
 Call Customer Service at 651-674-4491 to obtain prior approval or warranty will be denied.
 Date of Authorization Request _____

Equipment Owner		Warranty to be Performed by		
Customer Name		Company Name		
Street Address		Address		
City/State/Zip		City/State/Zip		
Equipment Model #		Contact Name		
Equipment VIN		Contact Phone #		
Hour Meter Read				
Purchase Date		Date of Malfunction		
Dealer Purchased Form		Date of Repair		
Warranty Authorization		Signature for Authorization		
Date of Malfunction		X		
Date of Repair				
Symptoms / Diagnostics / Action				
Symptoms	Diagnostics	Action		
<i>Describe the symptoms in detail, be as specific as possible. Ex: Burner ignites and runs for 35 seconds, then goes out.</i>	<i>Describe issues found, be as specific as possible. Ex: Part failed due to loose connection, resulting in misalignment and premature wear.</i>	<i>Describe action taken, be as specific as possible. Ex: Removed damaged section of wire harness, soldered new leads in place, and insulated splices w/ heat shrink tubing.</i>		
Parts and Labor				
Labor Time to Correct Problem (reimbursed at \$55/hour)		Parts Used to Correct Problem		
Labor Time (in hours)	Repair Made	Part Number	Description	Qty
Parts Return				
<p>All parts returned must be tagged with the warranty authorization number and a copy of this claim. Retain all parts until credit is received from the factory. When requested, return the parts, along with this claim, to:</p> <p style="text-align: center;">Stepp Manufacturing Co., Inc. Attn: Warranty Department 12325 River Road North Branch MN 55056</p> <p>*Note: If defective parts are not returned within 10 days, or this warranty claim does not accompany the returned parts, the claim will be denied.</p>				
Office Use Only				
Date Claim/Parts Received?		Is this a warrantable claim?	Yes	No
Claim Reviewed By:		Original Invoice # for Parts		
Date of Review:				
Warranty Totals				

WATLOW PROGRAMMING

Watlow 12v Series PM Temperature Controller

Operators Programming Sequence for 12 volt devices. PN EZ-ZONE– P1003540

This programming sequence is taken from the manufacturers programming manual for this controller and reduced to eliminate the non-essential entries. Please follow the entries carefully and if any questions arise because of misunderstanding the instructions, see your supervisor or call the factory for clarification. **To view the entire EZ-Zone PM Controller Users Manual, go to www.watlow.com, search on *EZONE PM Users Manual*.**

If at any time during the entries you feel that you have entered an incorrect entry and want to restart the procedure from the beginning, simply press the Infinity key to return to Home Page from any page or parameter. After 60 seconds with no key presses, the controller reverts to the Home Page.



The EZ-Zone PM Controller has four menus that are used to determine the configuration and operation of the controller. They are the Home Page, Setup Page, Operations Parameters Page, and the Factory Page. If you are installing the EZ-Zone PM Controller, you will need to determine the proper settings for all pages. The controller is preset at the factory prior to delivery of the equipment and is ready for operations. Always confirm that the controller is programmed correctly and operating correctly under normal operating conditions.

Caution: Pay particular attention to the h.SP (High Temperature Set point) setting for max. product application temperature that is entered on the Setup Page at step 7-8.

Do not set the High Temperature Set Point any higher than the product manufacturer maximum application temperature recommendations. Do not hesitate to ask your supervisor or call the factory for the correct setting if any questions or concerns arise.

Watlow Series PM-12 volt controller Sample Display Illustrations

- This display shows a typical temperature selection by the operator.
- Upper display shows actual product temperature in red color.
- Lower display shows operator desired maximum temp setting in green color.
- Set the desired maximum temp with the up and down keys.



Operator will not be able to exceed the maximum temperature set point as shown in the programming procedure in the following pages.

Do not hesitate to ask your supervisor for the correct setting if any questions or concerns arise.

Watlow Series PM-12volt Temperature Controller

Operators Programming Sequence for 12 volt devices

This programming sequence is taken from the manufacturers programming manual for this controller and condensed to eliminate the non-essential entries for ease of setup. Please follow the entries carefully and if any questions arise because of misunderstanding the instructions, please call the manufacturer for clarification.

If at any time during the entries you feel that you have entered an incorrect entry and want to restart the procedure from the beginning, simply press the up arrow and the down arrow at the same time to erase all entries and begin the procedure from the beginning.

Menu Structure and Programming

The Series PM Controller has four menus that are used to determine the configuration and operation of the controller. They are the Home Menu, Setup Menu, Operations Menu and the Factory Menu. If you are installing the Series PM Controller, you will need to determine the proper settings for all menus. If the controller is already installed in the equipment that you have purchased, you may only need to set a few of the parameters to adjust the controller to your specific usage of the equipment. The Setup Menu displays the parameters that configure the Series PM Controller to fit your application. When installed on new equipment, the controller is preset at the factory prior to delivery of the equipment and is ready for operations. Always confirm that the controller is programmed correctly and operating correctly under normal operating conditions.

Caution: Pay particular attention to the h.SP setting for max. product temperature. Do not set any higher than the product manufacturer maximum application temperature. Do not hesitate to ask your supervisor for the correct setting if any questions or concerns arise.

Watlow Series PM-12volt Temperature Controller

Operators Programming Sequence for 12 volt devices

Home Menu:

Procedure for programming the Series PM-12 volt Watlow Control.

Step 1: Connect all wires to Watlow control including RTD (temp sensor).

Step 2: Connect power to Watlow controller.

Step 3: Enter the Setup menu. (press both the **up and down** arrow keys for 6 seconds).
A1 will appear in the upper display and SEt will appear in the lower display.

Note:

*You will have to pass through the Operations menu to get to the Setup menu.
Hold the up and down arrow keys simultaneously for 6 seconds to step through the menus.*

Step 4: Once A1 is in the upper display, and SEt is in the lower display, you are in the Setup menu. If not, press the **infinity key** to return to the Home page and redo step 3.

Step 5: Press the **Advance key**. Use the **up or down** keys to change values.

	<u>Parameter</u>	<u>Value</u>	<u>Description</u>	<u>Caution</u>
5-1	SEn Advance key	ro.1H	sensor type	Do not enter { rl.OH }
5-2	rt.L Advance key	2	RTD leads	
5-3	FiL Advance key	0.5	Filler type	
5-4	i.Er Advance key	off	error latching	
5-5	dEC Advance key	0	decimal	

Step 6: After pressing the **Advance key**, after parameter dEC, you will return to the parameter .SEn. Press the **infinity** key to return to the Setup menu. Display will show { Ai Set }.

Step 7: Press either the **up or down** key to select the Loop submenu. **LOOP** will be in the upper display and **SEt** will be in the lower display. If this is shown, press the **advance key** to enter the Loop submenu. (once in the submenu, use the **up or down** key to change the parameter values).

	<u>Parameter</u>	<u>Value</u>	<u>Description</u>
7-1	h.Ag Advance key	on.of	heat algorithm
7-2	C.Ag Advance key	off	cool algorithm
7-3	UfA Advance key	off	user fail action
7-4	fAiL Advance key	off	input error failure
7-5	LodE Advance key	no	open loop detect enable
7-6	rP Advance key	off	ramp action
7-7	L.SP Advance key	0 degrees	low temperature set point(degrees)
7-8	h.SP Advance key	250 or 550	high temperature set point(degrees)
7-9	SP.Lo Advance key	-100.0	set point, low limit open loop
7-10	SP.Hi Advance key	100.0	set point, high limit open loop

Step 8: Pressing the **advance key** after parameter **SP.hi** will return you to the parameter **h.Ag**. Press the **infinity key** once to return to the setup menu.

Step 9: Use the **up or down** keys to select the output submenu. **otPt** will be in the upper display, and **SEt** will be in lower display. Press the **Advance key** to enter the submenu.

	<u>Parameter</u>	<u>Value</u>	<u>Description</u>
	(use the up or down key to change parameter values)		
9-1	Fn Advance key	heat	Function
9-2	o.tb Advance key	20.0	time base
9-3	O.LO Advance key	0%	low power scale
9-4	o.h1 Advance key	100%	high power scale

Step 10: Pressing the **advance key** after parameter **o.h1** will return you to parameter **Fn**. Press the **infinity key** to return to the output submenu.

Step 11: Use the **up or down** keys to select the global submenu **gLbL** will be in the upper display and **SEt** will be in the lower display. Press the **advance key** to enter the global menu.

	<u>Parameter</u>	<u>Value</u>	<u>Description</u>
11-1	C_F Advance key	F	display units
11-2	AC.LF Advance key	60	AC line frequency

Step 12: After pressing the **advance key** at parameter **AC.LF** will advance you back to parameter **C_F**. Press the **infinity key** once to return to the global submenu.

Step 13: Use the **up or down** keys to select the communication submenu. **Cor7** will be in the upper display and **SEt** will be in the lower display. Press the **advance key** to enter the communications submenu.

	<u>Parameter</u>	<u>Value</u>	<u>Description</u>
13-1	Ad.5 Advance key	1	Address Standard Bus

Step 14: Pressing the **advance key** on parameter **Ad.5** will advance you back to the same parameter, **ie.** you will still see parameter **Ad.5** displayed. Press the **infinity key** once to return to the communications sub menu.

Step 15: Press the **infinity key** to return to the Home page.

Step 16: From the Home page, press both the **up and down** keys for (3) seconds, **Ai** will appear in the upper display and **oPEr** will appear in the lower display.

Operations Page

Step 17: Once **Fli** is in the upper display and **oPEr** is in the lower display, you are at the Operations menu. If not, press the **infinity key** to return to the Home menu and redo step 16.

Step 18: Press the **up and down** keys until **LooP** is in the upper display and **oPEr** is in the lower display. Press the **advance key** to enter the **LooP** sub menu.

	<u>Parameter</u>	<u>Value</u>	<u>Description</u>
	(use the up or down keys to change values)		
18-1	C.r7 Advance key	auto	control mode
18-2	C.SP Advance key	75	closed loop setpoint

	<u>Parameter</u>	<u>Value</u>	<u>Description</u>
18-3	id.5 Advance key	75 degree F.	Idle set point
18-4	h.hy Advance key	3.0 degree F.	Heat hysteresis reads 3 on display
18-5	o.SP Advance key	0.0%	Open loop set point

Step 19: Pressing the **advance key** at parameter **o.SP** will advance you back to parameter **C.r7**. Press the **infinity key** once to return you to operations Loop menu. Press the **infinity key** again to return you to the Home Page.

Step 20: Enter the Factory Page by pressing the **advance key** and **infinity keys** together and holding them for six (6) seconds. **CUSr** will be in the upper display and **FCty** will be in the lower display.

Factory Page

Step 21: Once **CUSr** is in the upper display and **FCty** is in the lower display, you are in the Factory menu. If not, press the **infinity key** to return to the Home Page and redo step 20.

Step 22: Press the advance key if **CUSr** is in the upper display and **FCty** is in the lower display. The upper display will now read **1** and the lower display will read **CUSr**. Press the **advance key** again.

Step 23: The upper display will read **AC.Pu** and the lower display will read **PAr**. If the upper display does not read this way, use the **up and down** keys to change the value. Once the value has been changed, press the **infinity key** once.

Step 24: The upper display will read **1** and the lower display will read **CUSr**. Use the **up or down** keys to change the upper display to read **2**, press the **advance key**.

Step 25: The upper display will read **AC.SP** and the lower display will read **PAr**. If the upper display reads differently, use the **up or down** keys to change it to **AC.SP**. Once complete, press the **infinity key** once.

Step 26: The upper display will read **2** and the lower display will read **CUSr**. Use the **up or down** keys to change the upper display to read **3**. Press the **advance key** once.

Step 27: The upper display will read some parameter or other, and the lower display will read **PAr**. Use the **up or down** keys to change the upper display to read **none**.

Once complete, press the **infinity key**.

Step 28: Repeat steps 26 and 27 for display values of 4 through 20, changing each parameter to **nonE**.

Note: *The upper display will show the previous value you changed. You must increment this value from 4 through 20!*

Step 29: When all 20 parameters are set, press the **infinity key** once to return you to the main Factory Page, **CUS** will be in the upper display and **FC** will be in the lower display.

Step 30: Use the **up or down** keys to move to the Lockout submenu. **LoC** will be in the upper display and **FC** will be in the lower display. Press the **advance key** to enter the Lockout submenu.

	<u>Parameter</u>	<u>Value</u>	<u>Description</u>
	(use the up or down keys to change parameter values)		
30-1	LoC.o	2	Lock Operations Page
	Advance key		
30-2	rLoC	1	Read Lockout Security
	Advance key		
30-3	SLoC	1	Set Lockout Security
	Advance key		

Step 31: Pressing the **advance key** at parameter **SLoC** will advance you to back to parameter **LoC.o**. Press the **infinity key** to return you to the Lockout submenu.

Step 32: Press the **infinity key** again to return you to the Home page.

Congratulations! Programming is Complete.

SCHEMATICS

ONE BURNER CONTROL WIRING

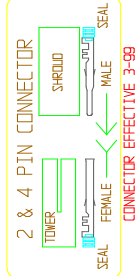
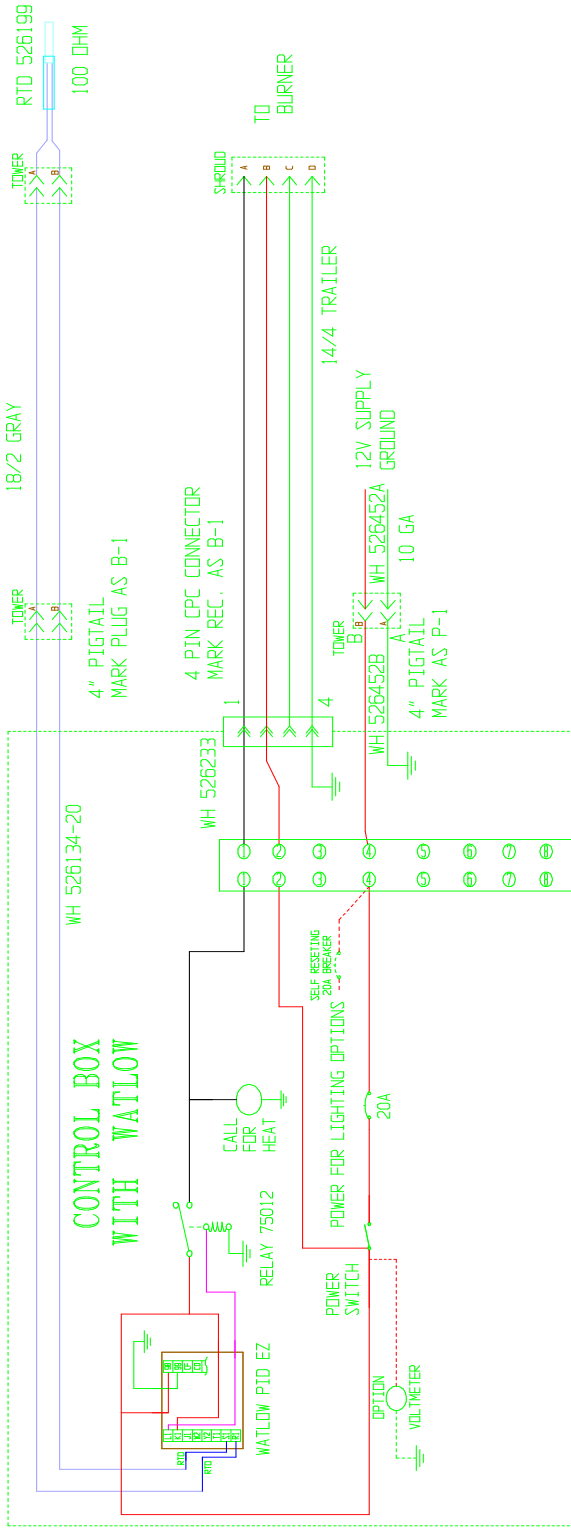

NOTE: CONNECT GROUND WIRES TO GROUNDING BAR IN CONTROL BOX

BURNER 1 CALL 4 HEAT BURNER 1 POWER	
12V SUPPLY	

LL	KL	JL	NL	YL	TL	SL	RL
98	99	CF	CO	CE	95	96	95

TERMINAL STRIP LABEL

ROUTING: -	CAGE CODE: 06447	ASS'Y: ONE BURNER CONTROL
DWN: 4-08	DWN BY: JD	PART NAME: WIRING DIAGRAM
REV: -	REV: -	FILE NAME: 12VIB-WAT-EZ
INV NO: -	INV NO: -	QTY: 1
MAT'L: AS NOTED	MAT'L: AS NOTED	JOB NO: 1
<p>WH 526134-20</p> <p>CONTROL BOX WITH WATLOW</p> <p>WATLOW PID EZ</p> <p>RELAY 75012</p> <p>CALL FOR HEAT</p> <p>POWER SWITCH</p> <p>POWER FOR LIGHTING OPTIONS</p> <p>20A</p> <p>SELF RESETING 20A BREAKER</p> <p>4" PIGTAIL MARK PLUG AS B-1</p> <p>4 PIN CPC CONNECTOR MARK REC. AS B-1</p> <p>12V SUPPLY</p> <p>GROUND</p> <p>10 GA</p> <p>WH 526452A</p> <p>10 GA</p> <p>WH 526452B</p> <p>4" PIGTAIL MARK AS P-1</p> <p>14/4 TRAILER</p> <p>TO BURNER</p> <p>SHROUD</p> <p>A</p> <p>B</p> <p>C</p> <p>D</p> <p>18/2 GRAY</p> <p>RTD 526199</p> <p>100 OHM</p> <p>TOWER</p> <p>TOWER</p>		
<p>SHOP NOTES</p> <p>STANDARD SHOP TOLERANCE UNLESS OTHERWISE NOTED: ±1/16" & ±1°</p>		
<p>MACHINE CODE</p> <p>LOCK FORMER: -</p> <p>WIEDERMANN: -</p> <p>LARGE BRAKE: -</p>		
<p>NOT TO BE REPRODUCED IN ANY FORM WITHOUT THE EXPRESSED WRITTEN PERMISSION OF STEPP MFG CO INC</p>		
<p>STEPP MFG CO INC</p> <p>NORTH BRANCH, MN. 55056</p>		

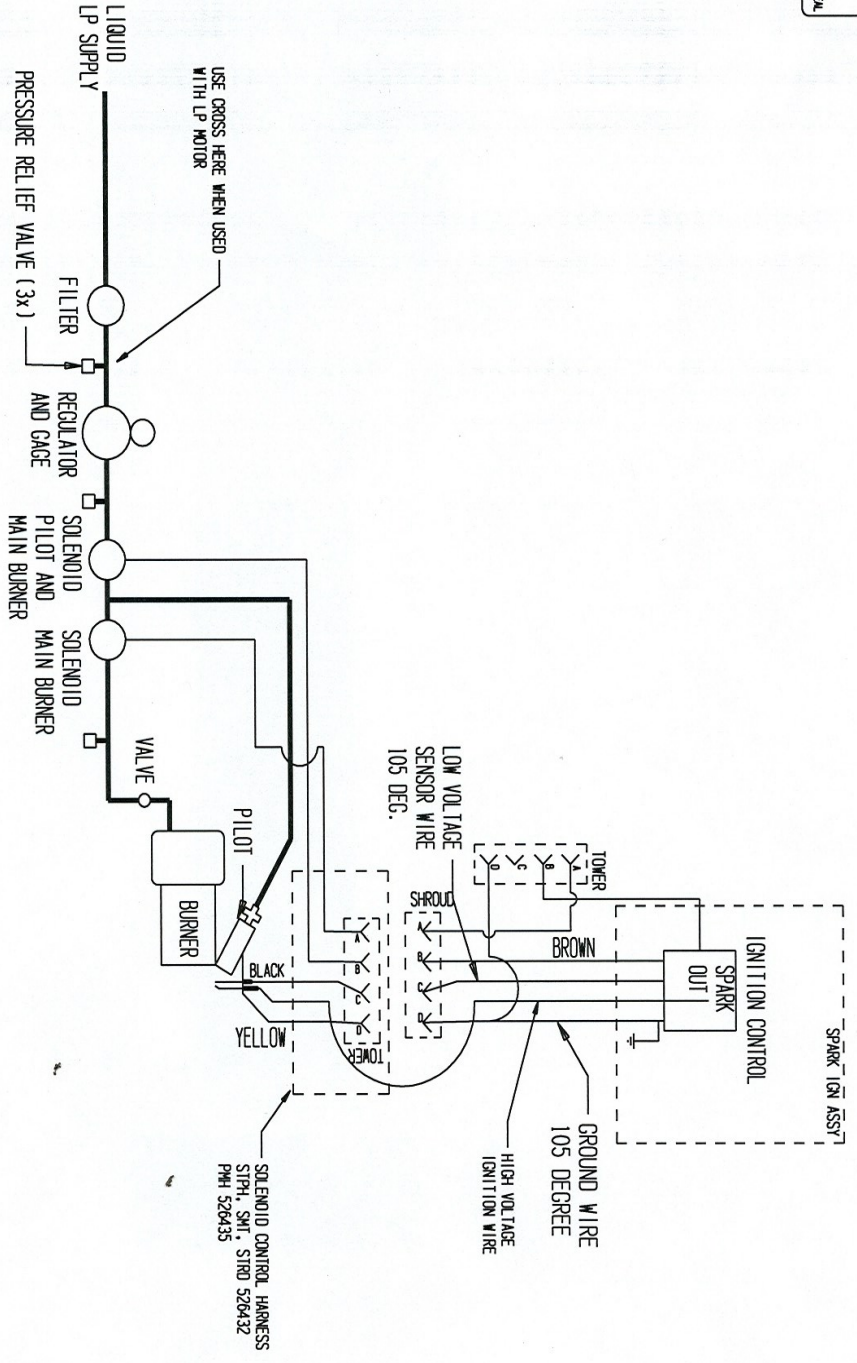
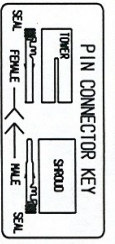

Rev: 12-05 added control box print ref.

SHOP NOTES		MACHINE CODE	
STANDARD SHOP TOLERANCE UNLESS OTHERWISE NOTED: ±1/16" & ±1°			
LOCK FORNER:	WIEDERMAN:	MACHINE CODE	
LARGE BRAKE:			
 STEPP MFG CO INC. NORTH BRANCH, WI. 53056		ROUTING:	
		CAGE CODE: 06447	ASS'Y:
NOT TO BE REPRODUCED IN ANY FORM WITHOUT THE EXPRESSED WRITTEN PERMISSION OF STEPP MFG CO INC.		DWN: 3/04	DWN BY: CPM
		REV: 12/05	FILE NAMR: HEATSP
		INV NO:	INV ANT BA:
		MAT'L: AS NOTED	JOB NO:
			JOB QTY:
			JOB QTY:
			JOB QTY: