

OJK



Stepp OJK-Vertical Crack Sealers With
SMART TECHNOLOGY

 **STEPP MFG**
ASPHALT MAINTENANCE EQUIPMENT
651-674-4491 / STEPPMFG.COM

Industry Leading Crack Sealing Technology

Solving Problems, Addressing Needs

At Stepp Manufacturing, our engineers produce equipment that is known in the industry for its durability, reliability and functionality. Since our beginning in 1942, our family owned operation has always produced equipment specific to your needs. We use high quality material, innovative engineering, and quality personnel to match your needs as they grow.

Welcome to the Future of Crack Sealing

Stepp Manufacturing has always been an industry leader in technology with crack sealing equipment, and with our new OJK-V line of crack sealers, we continue to be the number one choice for crack sealing equipment. With over 35 new design innovations on our OJK-V series, we took a great machine and made it even better!

The Stepp Mfg Oil Jacketed (double boiler) Asphalt Crack Sealing Kettle is used to melt rubberized crack sealing and water proofing compounds and apply them to roads, parking lots, and bridge decks to repair and seal cracks. The Stepp OJK-V Oil Jacketed Asphalt Crack Sealing Kettles are offered with a wide range of options from LPG or Diesel fired configurations and gravity flow or full pumping configurations. Our OJK-V crack sealer is trailer mounted and completely self-contained, meaning it is capable of heating, melting, and applying all grades of rubberized asphalt crack sealer, joint sealants, and waterproofing compounds without the need for additional equipment. Our vertical Crack Sealing Kettles are designed for quick heat up times and are very simple to use and operate. Our optional submerged pump eliminates freeze-ups by allowing the pump to heat with the material. A splash-free safety loading chute ensures safe operation; couple that with the heated overhead boom and auto-loading system, and you have the ultimate crack sealing machine.



OJK V Series

STEPP ASPHALT CRACKSEALER LINE



- ① 75 or 125 Gallon Tank Options**
- ② LP or Diesel Fired Options**
- ③ AKC Smart Technology / CAN Bus Control System**
- ④ Gravity Flow or Optional Pumping System with Heated Hose System**
- ⑤ Kubota Diesel Engine / Kohler LPG Engines / Honda Gasoline Engine**
- ⑥ Optional Removable Bolt-on Submerged Pumping System**
- ⑦ Optional Heated Overhead Boom**
- ⑧ Optional Ultra-Light Hose Smooth Bore Teflon and Aluminum Trigger Wand**
- ⑨ One-piece Bolt-on Shackles - 250% Stronger than the Competition**
- ⑩ Optional 100 CFM Rotary Screw Air Compressor**

Industry Leading Crack Sealing Equipment



Industry Leading Crack Sealing Equipment



Air Compressor model



75 gallon



Knowledge-Technology-Innovation and Safety Driven Designs

With over 100 of years of combined industry experiences in our sales, engineering, and production team, we offer what few companies can - "Wisdom" in our product designs

Stepp AKC Advanced Kettle Controls

The OJK-V series of crack sealing kettles now boasts an all-in-one PLC CAN bus control system. The AKC controller monitors and controls all burner functions, the heated hose, pumping and agitation controls, kettle interlock safety systems, autoloader controls and operations, auger safety shutdown, pump hours, and diagnostics for the burner control system. The AKC integrates all burner and hydraulic controls into a simple, easy-to-use control package.

Smart Control Burner Interlock

The AKC controller includes a burner interlock system. This will not let the operator activate the pumping system or agitator until the material has reached it's interlock temperature. This prevents premature wear on the pumping system and unnecessary hydraulic load. The AKC controller also displays a warning message on the screen and a boom mounted warning light. The warning messages include burner interlock, RTD failure (temp sensor), door open/close, and agitator shutdown. You can also choose between US and Metric settings.

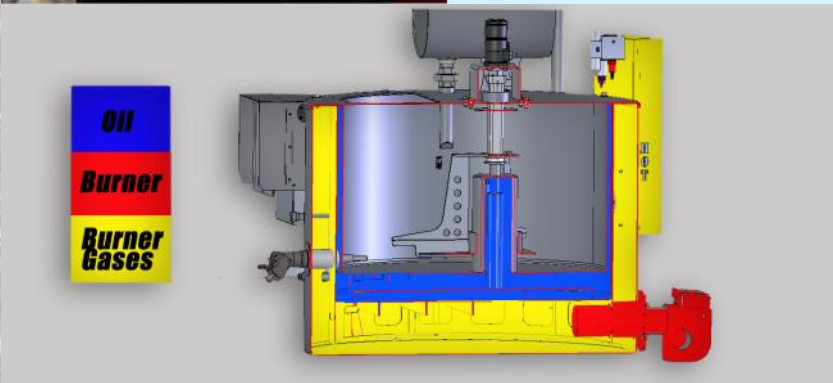

Vertical Kettle Design with Center Heat Riser

The Stepp Ojk-V offers the most heated surface area in the industry. With our center heat riser and fully surrounded oil jacket we are giving you the highest amount of heat transfer capable.

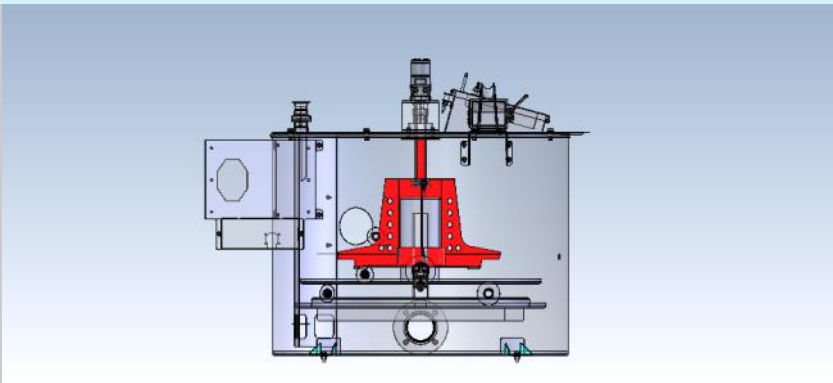

Full Sweep Agitator

The Ojk-V has a internal, vertical mixer with 3 opposing paddles that not only mix but also lift to add complete agitation within the kettle.

Knowledge-Technology-Innovation and Safety Driven Designs

Standard Equipment Available on the Stepp OJK-H Crack Sealers

LPG Kohler® Powered (only available on propane fired units)

Our LP fired Ojk-V features a Kohler LPG fired engine. The Propane fired and propane engine offer a reliable power plant in a less expensive option. The Kohler LPG engine offers electric start, 20 HP air cooled, LP gas carbureted, direct coupled to the hydraulic pump.

Diesel Kubota® Powered

Having a quality machine means having quality components, and our engine is no exception. The liquid cooled, two cylinder, 16HP, Kubota Z605 is what powers our workhorse crack sealers. It uses a direct coupled tandem hydraulic pump and a direct mounted 24 volt alternator to power our heated overhead boom and hydraulic components. The new Deep Sea digital engine management system, batwing engine enclosure, and anti-vibration engine mounts make this a quiet, trouble free power plant.

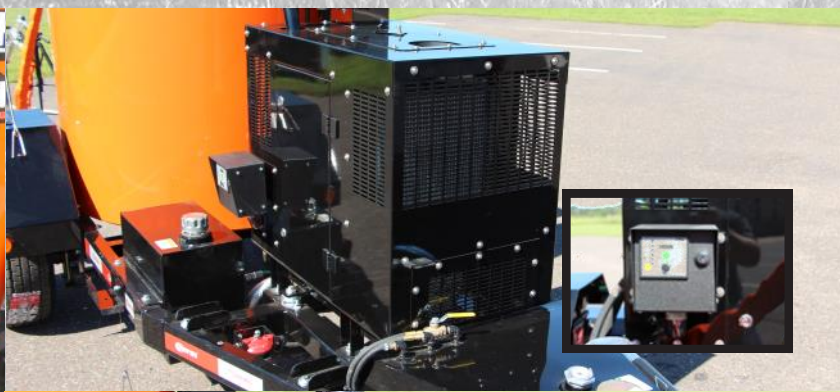

Deep Sea Digital Engine Management System

The Deep Sea digital engine management incorporates the hour meter, volt meter, low oil shutdown, overheat shutdown, and cold weather glow plug operation into one easy-to-operate controller. We also include an unloader button to relieve the hydraulic system pressure during cold weather starting.

Anti-Vibration Engine Mount

The OJK-H boasts an all-in-one hydraulic tank, fuel tank, and motor mount system. This incorporates the anti-vibration engine mounts, engine enclosure, radiator mount, and 24 volt alternator mount. The fuel tank and hydraulic tank each have a 28 gallon capacity reservoir and include a return filter.

Engineered Excellence

“Industry leaders with industry leading technologies”

We have pioneered many of the industry’s leading designs such as the Electric Heated Hose, PLC CAN Bus Controls, Overhead Boom, Exact-Flow Wand Control, and the On-demand Pumping System

Optional Variable Speed, On-demand, Removable, Submerged Pumping System

The OJK-V boasts a submerged 20GPM Roper gear pump for years of durable service. By submerging the pump, we can ensure that it is hot and ready to go as soon as the sealant is up to temperature. The variable speed control is located in the control box or, with the optional exact-flow wand control, on the wand. We have also designed the pump to be easily replaced with the top mounted flange and allows replacement without having to drain the kettle.

Optional Heated Overhead Boom

The redesigned electric heated overhead boom and ultra-lite hose are just two of the many new features of the OJK-H kettles. The relocated overhead boom allows for optimum operator reach with a shorter, lighter hose to carry. The unique design sends heated product through the boom to the attached hose. With the standard 12’ hose attached to the 6’ overhead boom, the operator will get over 21’ of work area. The boom also puts the operator in a better position for increased visibility.



Ultra-Lite Hose and Wand

The new ultra-lite Teflon hose with a stainless steel liner gives the operator flexibility without the ability to kink and damage the hose. The 24 volt DC internal heating elements make for fast heat up times and operator safety, and are replaceable without having to replace the hose, making this an affordable, serviceable item. Standard with the ultra-lite hose is the ultra-lite wand.

Ultra-Lite Wand with On-Demand Pump Saver

The ultra-lite wand system incorporates an on-demand pumping system, or a “Pump Saver”, which only pressurizes the hose and wand when applying sealant. This allows safe and efficient pumping procedures with a trigger controlled switch. Couple that with the optional exact-flow wand control option, and you have the ability to adjust the product flow on the fly from the wand handle so you can tackle any and all types and sizes of cracks.

Knowledge-Technology-Innovation and Safety Driven Designs

Standard Equipment available on the Stepp OJK-H Crack Sealers

MTF Frame System with Shackle Simplicity

The Modular Tubular Frame (MTF) system is truly the foundation of our units. Our MTF frame offers flexibility, maintainability, and extreme reliability. Our bolt-on module system allows for components and options to be bolted on, allowing flexibility in your configuration. The MTF frame also allows us to use our one-piece, bolt-on shackle system, "Shackle Simplicity". This true tracking shackle system is 250% more heavy duty than anything else on the market. Our MTF frame with "Shackle Simplicity" is just another example of our industry leading technologies and designs.

Loading Chutes with Agitator Shutdown

The Stepp OJK-H includes a standard dual safety loading chute with standard agitator shutdown sensors to stop the auger when the doors are open to prevent material splashing. Use the loading chutes for safe and easy splash-free loading from either side of the machine.

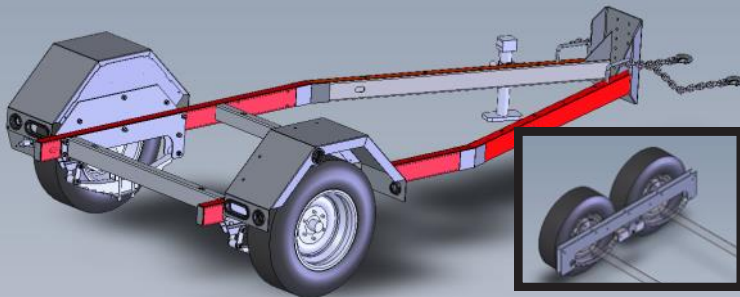

Standard LED Lights

The Stepp OJK-H includes LED lights as standard equipment. Stop-tail-turn lights, 3 light bar, marker lights, and clearance lights. Mounted in grommets for easy replacement.

75 Gallon on & 125 Gallon Size Options

The Stepp OJK-V comes in 2 different sizes to meet your needs. The 75 will meet most of the average demands of small cities or contractors. Our 125 gallon kettle is our most popular size, covering most mid-sized contractors and municipalities.

Options That Bring Value, Productivity and Safety

Optional Equipment available on the Stepp OJK-H Crack Sealers

Exact-Flow Wand Control

The optional exact-flow wand control allows the operator to adjust the material flow from the wand handle without going back to the machine. The conveniently located rheostat controls the hydraulic flow to the product pump. Another option to get your job done faster and more efficiently.

100CFM@100PSI Rotary Screw Compressor

A Rotorcomp EVO3-NK 100CFM@100PSI air compressor may also be installed onto the unit to aid in the cleaning of debris from the crack. Our compressor is the REAL DEAL. It is directly coupled to a Kubota V3300 diesel engine rated at 44.1HP@2600RPM and includes an intake valve, oil cooler, hi-temp shutdown, oil filter, minimum pressure valve, separator head, pressure gauge, and shuttle valve to maintain constant engine speeds. No belts, no chains, just more air to get the job done!



Electric Overnight Heat

110 volt electric overnight heaters help speed up the heating time when you arrive on the jobsite first thing in the morning. It is an option that pays for itself in decreased man hours in just the first week of operation. This is a must have option for crews of all sizes, and just another way Stepp has helped you be more productive and save money.

Autoloader with True Loading Technology

Stepp has designed this system for automatic operation once loaded. It eliminates the need for personnel to be in a dangerous position in the bed of the towing vehicle while in motion. Once the conveyor is loaded, it will automatically advance to place additional material into the kettle at a rate equal to that of the material being dispensed, making it the only autoloader on the market that is "truly automatic".

OJK 75**OJK 125**

Shipping Weight	2400#	3350#
GVWR	5660#	5660#
Length x Width x Height	210"x90"x85"	167"x77"x91"
Material Capacity	75 Gallons	125 Gallons
Fuel Tank Capacity	28 Gallons	28 Gallons
Hyd Tank Capacity	10 Gallons	Gallons
Tank Construction	10ga Tank 10ga Oil Jacket 12ga	10ga Tank 10ga Oil Jacket 12ga
Tank Configuration	Horizontal	Horizontal
Loading Height	46"	52"
Heat Transfer Oil	ISO VG 68 with 600°F C.O.C. Flash	ISO VG 68 with 600°F C.O.C.
HTO Capacity	33 Gallons	33 Gallons
Controls	AKC Advanced Kettle Control all-in-one	AKC Advanced Kettle Control all-in-one
Burner Type and Output	Diesel 240,000 BTU with Full-Flow	Diesel 240,000 BTU with Full-Flow
Hose Style	Heated Ultra-Lite 3/4" Smooth Bore	Heated Ultra-Lite 3/4" Smooth Bore
Boom	24V Electric Heated	24V Electric Heated
Pump	Roper 17A21 Submerged Gear with Easy Access Design	Roper 17A21 Submerged Gear with Easy Access Design
Product Pump GPM	20 GPM with variable range 0-10	20 GPM with variable range 0-10
Wand	Ultra-Lite Electrically Heated with	Ultra-Lite Electrically Heated with
Engine	Kohler 20Hp LPG, Honda 13hp Gasoline Kubota Z605 16 Hp w/Digital Engine Mgmt System	Kohler 20Hp LPG, Honda 13hp Gasoline Kubota Z605 16 Hp w/Digital Engine Mgmt System
Hydraulic Pump	Eaton .66 Cubic Inch	Eaton .66 Cubic Inch
Hitch Height	Adjustable 24"-32"	Adjustable 24"-32"
Frame Construction	2"x4"x3/16" Rectangular Steel Tub-	2"x4"x3/16" Rectangular Steel Tub-
Axles	6,000#	6,000#
Tires	(4) 225/75R15	(4) 225/75R15
Brakes	Electric (Hyd Optional)	Electric (Hyd Optional)
Hitch	3" Pintle or 2-5/16" Ball	3" Pintle or 2-5/16" Ball



Stepp Mfg has the Largest Line of Asphalt Maintenance Equipment in the Industry



Asphalt Hot Boxes & Reclaimers



Asphalt Patch Trucks



Asphalt Melters



Asphalt Kettles



Asphalt Recyclers



Asphalt Distributor Trailers

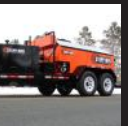

Asphalt Mastic Machines



Water Trucks

Stepp Manufacturing Co., Inc.
12325 River Rd
North Branch, MN 55056
651-674-4491

Visit Us on the Web! steppmfg.com ~ facebook.com/steppmfg