

Stepp Manufacturing Co Inc  
Model Stph-5.0 Pothole Patcher Truck Requirements

**Single Axle**

35,000# GVWR

12,000# Front Axle

23,000# Rear Axle

120" Cab to Axle Length

194" Wheelbase (may vary with different truck mfg)

**SINGLE AXLE TRUCK WILL NOT MEET US FEDERAL BRIDGE SPAN LAW.**

**Tandem Axle**

54,000# GVWR

14,000# Front Axle

40,000# Rear Axle

**Minimum Requirements**

**108" Cab to Trunnion (center of rear tandems)**

**174" Wheelbase (may vary with different truck mfg)**

**Transmission**

Automatic Transmission -Allison 3000 series transmission or equal. Must have left side (drivers) PTO flange and lock up torque converter.

Dipstick location as not interfere with PTO and hydraulic pump installation.

OR

Manual Transmission requires extended front bumper and capabilities for crankshaft driven PTO.

Stepp to supply PTO, pump, tank, and all motors and plumbing to operate hydraulic driven pumping system.

**Exhaust System**

We prefer a vertical exhaust system if possible. If exhaust system is overly large, we may need to extend the cab to axle to accommodate the larger stacks and mufflers. Please contact us if you have any questions.

**Clear Frame Space**

Spoils Bin. The spoils bin will be mounted on the curb side of the unit requiring 43" of free space. If interference with truck accessories is an issue, we can do custom mounts for an additional fee.

**Fuel Supply**

Open port in fuel tank to supply fuel to burner on patch body.

**Electrical**

7-way auxiliary connection at back of cab to supply stop, turn, taillights, and backup lights.

Must also be supplied with a 12-volt accessory/ignition connection and a 20-amp power and ground connection to supply electrical power to the body for controls, and any other electrical apparatus.

If you have any questions, please feel free to contact us at 651-674-4491.

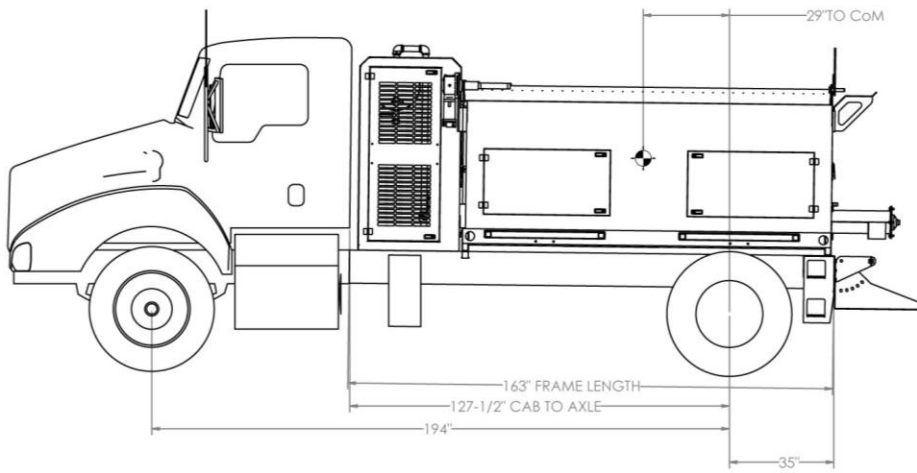

FRONT AXLE: 12,000 LB  
 REAR AXLE: 23,000 LB

CLEAR FRAME NEEDED FOR SPOILS BIN: 43"

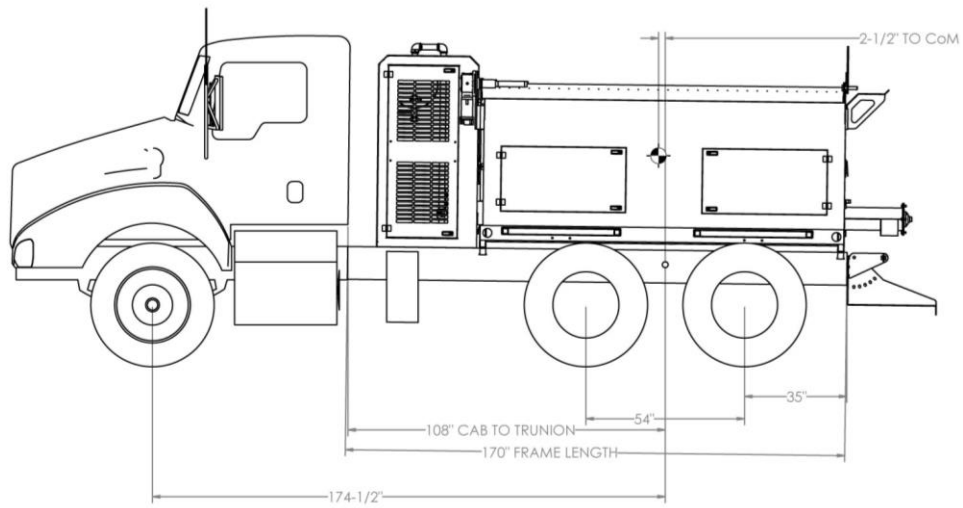

FRONT AXLE: 14,000 LB  
 REAR AXLE: 40,000 LB

CLEAR FRAME NEEDED FOR SPOILS BIN: 43"